

INTRODUCTION

The 16-pin data link connector adheres to the SAE J1962 standard. It is located on the driver's side on all vehicles sold in North America, starting with model year (MY) 1996. Figure 1.

- Pin 16 is 12-volt battery
- Pin #4 is chassis ground
- Pin #5 is the computer ground
- Pins #6 and 14 are CAN C (high speed) terminals on all 2008 and newer vehicles.

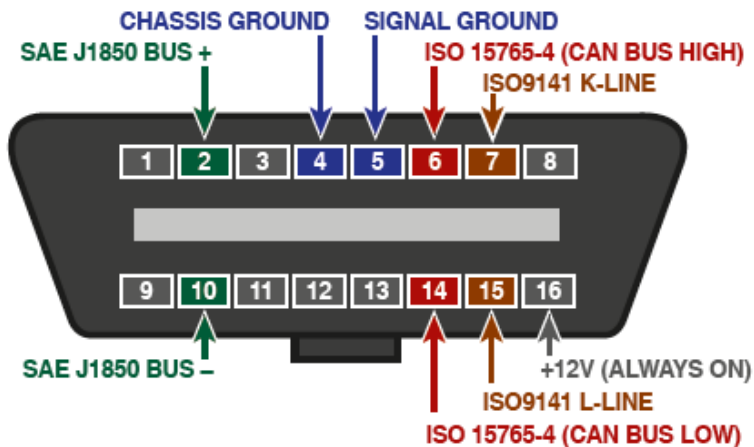

Figure 1. Data link connector (DLC) pins.

Factory scan tools are the scan tools required by all dealers that sell and service the brand of vehicle.

Examples of factory scan tools include (oldest to newest) the following:

- General Motors—Tech 2, MDI (Multiple Diagnostic Interface), MDI 2, or GDS2 (global diagnostic system 2). Figure 2.
- Ford—New Generation Star (NGS) and IDS (Integrated Diagnostic Software), VCM, VCM2, or VCM3, FDRS
- Chrysler—DRB-III, Star Scan, wiTECH, or wiTECH 2
- Honda—Master Tech, Honda Diagnostic System (HDS)
- Toyota—Master Tech or Tech Stream



Figure 2. The GM MDI2 connects between the DLC and a dedicated laptop computer to make up the complete scan tool.

Aftermarket diagnostic scan tools are manufactured by many manufacturers and use the data licensed from each original equipment manufacturer (OEM). These scan tools are sold by Snap-On, OTC/Bosch, Autel, and others. Figure 3.



Figure 3. Enhanced aftermarket scan tool.

A code reader is a low-cost scan tool that can display only global (generic) trouble codes. Generic scan tools provide only emissions-based information on the vehicle and are limited to PCM or engine data including:

- Read DTCs
- Clear DTCs

- Check and possibly reset readiness monitors.

ASE TEST TOPICS

1. Retrieve and record diagnostic trouble codes (DTCs), OBD II monitor status and freeze frame data.

DTCs. The diagnostic process determines what problems or symptoms are associated with the stored DTCs that need to be identified and addressed to find the root cause of the customer concern. The process starts with an all-module scan and includes checking service information, on-vehicle pin-point testing, and performing a visual inspection of the systems and components. The number in the hundredth position indicates the specific vehicle system or subgroup that failed. This position should be consistent for P0xxx and P1xxx type codes. The following numbers and systems were established by SAE:

- P0100—Air metering and fuel system fault
- P0200—Fuel system (fuel injector only) fault
- P0300—Ignition system or misfire fault
- P0400—Emission control system fault
- P0500—Idle speed control, vehicle speed (VS) sensor fault
- P0600—Computer output circuit (relay, solenoid, etc.) fault
- P0700—Transaxle, transmission faults

Monitor status. Most scan tools and code readers can display the status of the OBD-II monitors. Figure 4.

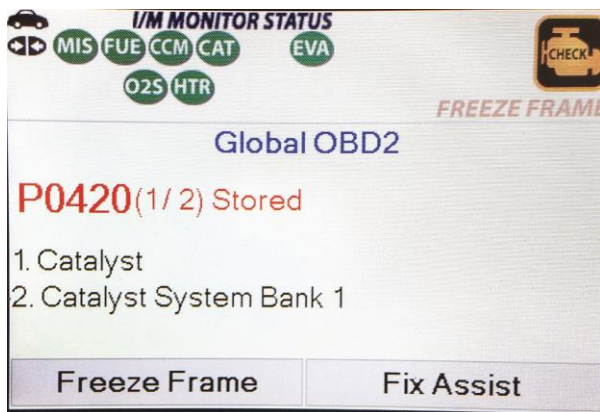

Figure 4. I/M monitor status indicated as “passed” by the green highlight.

Freeze frame. To assist the service technician, OBD-II requires the PCM to take a “snapshot” or freeze-frame of all data at the instant an emission-related DTC is set.

2. Research OBD II system operation; determine enable criteria for setting and clearing diagnostic trouble codes (DTCs) including permanent DTCs; determine malfunction indicator lamp (MIL) operation.

OBD-II regulations require that not only sensors but also all exhaust emission control devices be tested, and that they are verified for proper operation. The regulations for OBD-II vehicles state that the vehicle

computer must be capable of testing for, and determining, if the exhaust emissions are within 1.5 times the FTP limits.

A DTC should not be cleared from the vehicle computer memory unless the fault has been corrected, and the technician is so directed by the diagnostic procedure. If the problem that caused the DTC to be set has been corrected, the computer will automatically clear the DTC after 40 consecutive warm-up cycles with no further faults detected. (Misfire and excessively rich or lean condition codes require 80 warm-up cycles.)

Malfunction indicator operation

MIL Condition: Off - This condition indicates that the PCM has not detected any faults in an emissions-related component or system or that the MIL circuit is not working.

MIL Condition: On Steady - This condition indicates a fault in an emissions-related component or system that could affect the vehicle emission levels.

MIL Condition: Flashing - This condition indicates a misfire or fuel control system fault that could damage the catalytic converter.

Permanent codes. Starting in 2010 all vehicles support “permanent fault codes,” which are stored in nonvolatile RAM and cannot be cleared when the battery is disconnected and only go away when the problem is fixed. Permanent codes cannot be simply “cleared” by any tool, even factory scan tools. These codes can only be cleared by the PCM once it has determined that the malfunction is no longer present. This usually requires that the vehicle be driven enough so it can pass the self-tests.

3 . Diagnose the causes of emissions or driveability problems with stored or active diagnostic trouble codes (DTCs).

If a diagnostic trouble code (DTC) is present in the computer memory, it may be signaled by illuminating a malfunction indicator lamp (MIL), commonly labeled “check engine” or “service engine soon.” Some vehicles can display DTCs in the instrument cluster. Figure 5.



Figure 5. DTC P0122 indicates a Throttle/Pedal Position Sensor/Switch "A" Circuit Low Input.

4. Diagnose the causes of emissions or driveability problems without diagnostic trouble codes (DTCs).

About 80% of problems can be solved using a systematic approach and following the procedure for a particular DTC. However, for the remaining 20%, it is the skill and experience of the service technician that will help narrow the problem to the root cause, sometimes with no DTC set. Most manufacturers publish symptom based diagnosis in service information.

Intermittent driveability problems are usually difficult to find. Most experts recommend the following procedures that have successfully been used to locate those hard-to-find faults.

- With the engine running or the component operating, start wiggling the wires, connectors, and hoses. Watch for any change in the operation of the engine or components being moved.
- Use a water spray bottle that has a little salt added and spray all the electrical wiring and wiring connections. Watch for any change in the operation of the engine or component while spraying.
- Unplug all the electrical connectors and look for rust or corrosion. If possible, use a male metal terminal of the correct size and try mating it with the female terminal, checking to see if the terminal may be too loose to make proper contact. This test is called the “drag test,” also referred to as a “pull test.”

5. Use a scan tool, digital multimeter (DMM), or digital storage oscilloscope (DSO) to inspect or test computerized engine control system sensors, actuators, circuits, and powertrain/engine control module (PCM/ECM); determine needed action.

A scan tool is the easiest way to check PCM data. Specific, selected bits of data can tell the most about the operation of the engine control system. Some examples are:

With the key on, engine off (KOEO):

- Engine coolant temperature (ECT) is the same as intake air temperature (IAT) after the vehicle sits for several hours. MAP should equal BARO.
- With the key on, engine running (KOER), the upstream conventional zirconia oxygen sensor should switch rapidly within 200 mV and 800 mV.

A two-channel scope can display the waveform from two separate sensors or components at the same time. This feature is very helpful when testing the accelerator position sensor or brake switch inputs to ensure they change at the appropriate voltage levels. Figure 6.

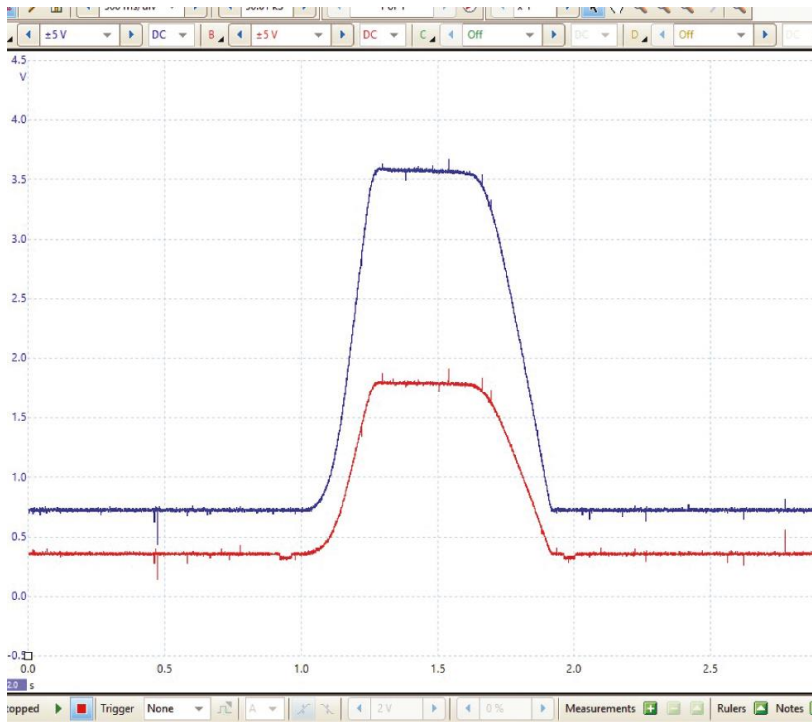

Figure 6. A two-channel scope being used to compare the two inputs from an accelerator pedal position (APP) sensor.

6. Measure and interpret voltage, voltage drop, amperage, and resistance using digital multimeter (DMM) readings.

Both the resistance (in ohms) and the voltage drop across a sensor can be measured and compared with specifications. Most engine sensors use a 5-volt reference and a ground. Before replacing the sensor that did not read correctly, measure both the 5-volt reference and ground. Figures 7 and 8.

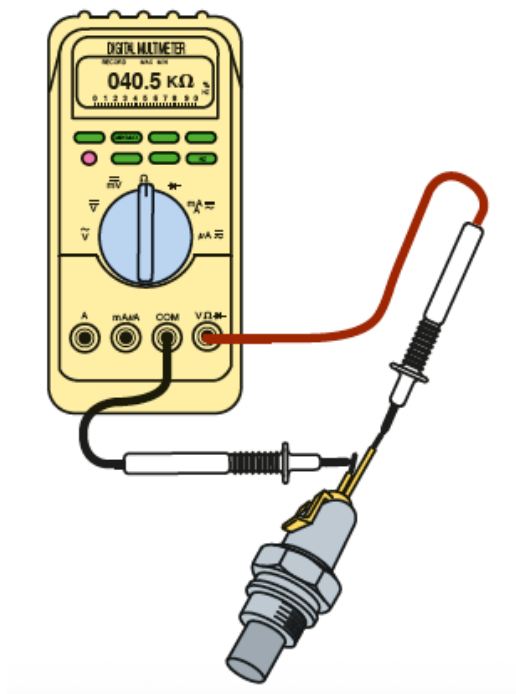

Figure 7. Checking the resistance of a coolant temperature sensor (CTS).



Figure 8. Measuring the reference voltage at a throttle position (TP) sensor.

To check the voltage drop in the sensor ground, turn the ignition on (engine off) and touch one test lead of a DMM set to read DC volts to the sensor ground and the other to the negative terminal of the battery. Any reading higher than 0.2 volt (200 mV) represents a poor ground. Figure 9.

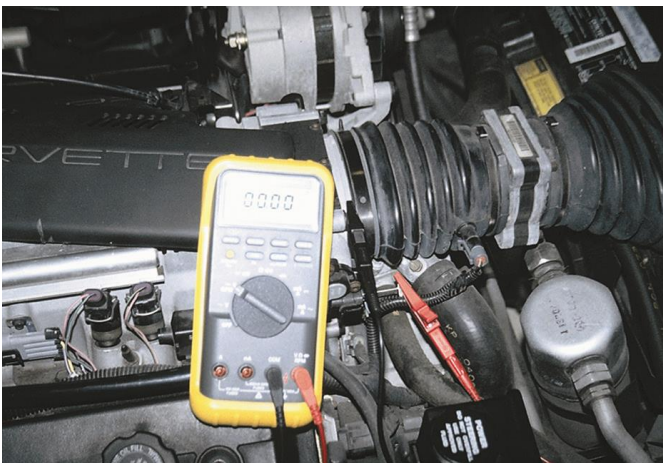

Figure 9. Checking voltage drop in the TP sensor ground.

7. Test, remove, inspect, clean, service, and repair or replace voltage supply and ground distribution circuits and connections.

Voltage supply distribution often are grouped together and protected by fuses. If these are under the hood they must be checked for tightness and corrosion. Figure 10.

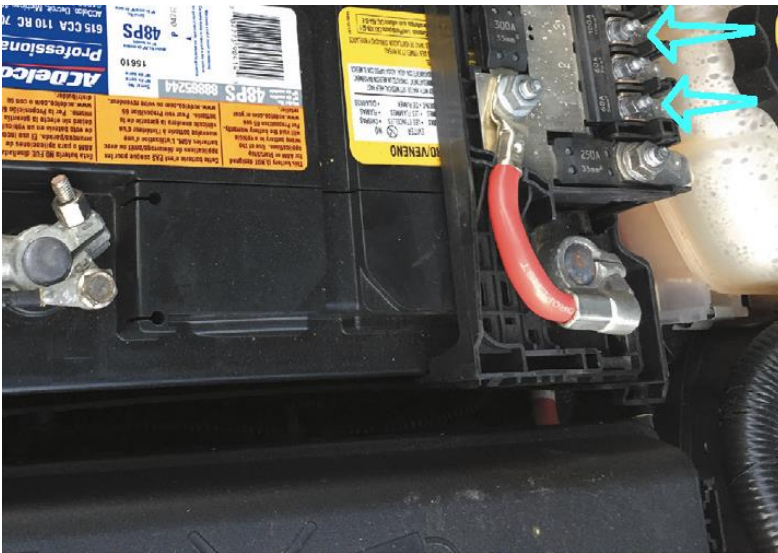

Figure 10. Power distribution points (arrows).

8. Inspect, test, and/or replace powertrain/engine control module (PCM/ECM); program, reprogram, code, initialize, and/or setup as needed.

Programming or reprogramming consists of downloading new calibrations from the manufacturer into the PCM's electronically erasable programmable read only memory (EEPROM). Any time a PCM is replaced it must be programmed or setup to match the vehicle's systems. Figure 11.

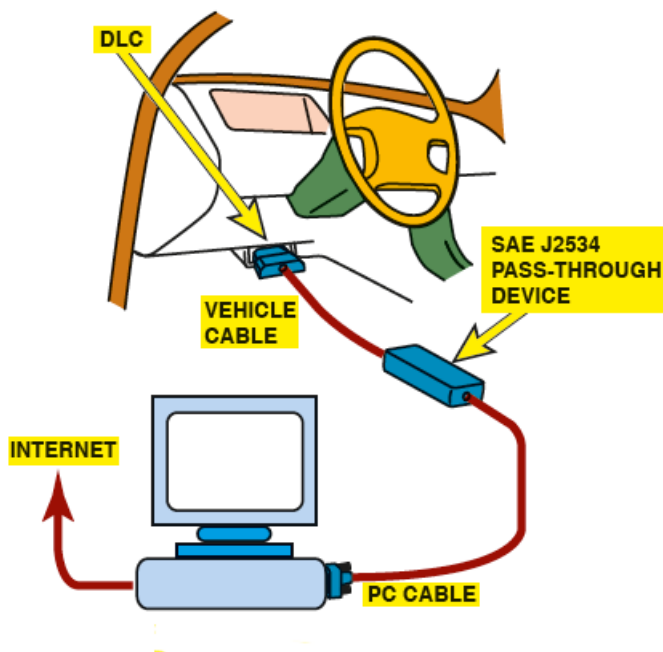

Figure 11. Programming loads from the manufacturers service information into the vehicle PCM.

9. Diagnose driveability and emissions problems resulting from failures of interrelated systems (for example: cruise control, security alarms/theft deterrent, torque controls, traction controls, torque management, A/C, non-OEM installed accessories).

Faults with the immobilizer system can be the cause of one of the following conditions depending on the exact make and model of a vehicle:

- No crank condition (the starter motor does not operate)
- The engine cranks but does not start (fuel disabled in most vehicles)
- The engine starts but then almost immediately stalls.

A flashing security warning light indicates that fault in the immobilizer system may be a possible cause rather than a fault with the ignition or fuel system. Figure 12.



Figure 12. A security system fault will cause the warning lamp to flash and may cause a no-start.

Traction control systems use accelerator reduction and engine power reduction to limit slip before applying the brakes to the wheel that is spinning. This may be perceived by the driver as an engine related fault. This can include some or all of the following:

- Retard spark timing
- Reduce injector on-time (pulse-width)
- Close or reduce the throttle opening
- Shift the automatic transmission to a higher gear

10. Diagnose failures in the data communications bus network; determine needed repairs.

A system of intercommunication between computers or processors is referred to as a network. By connecting the computers together on a communications network, they can easily share information back and forth. Beginning with 2008 models, all vehicles sold in the United States must a controller area network (CAN) BUS for scan tool communications. Figure 13.

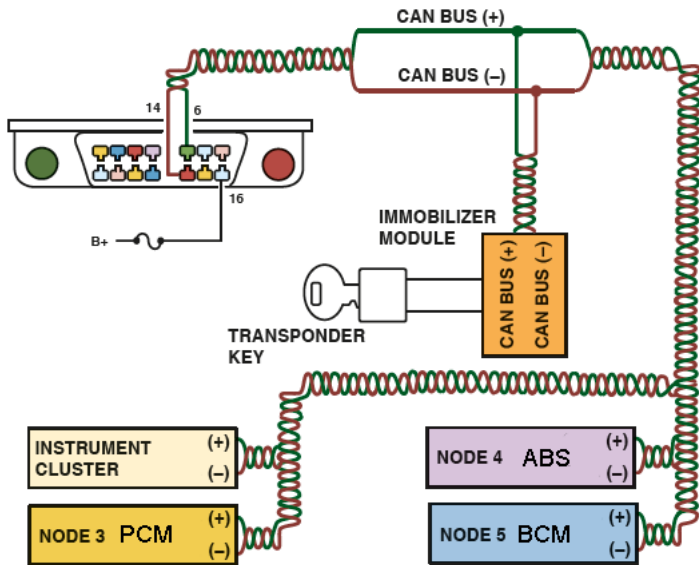

Figure 13. Example of a CAN BUS network.

Some characteristics of the CAN BUS that can be used during diagnosis are:

- Uses a 120 ohm resistor at the ends of each pair to reduce electrical noise.
- Applies 2.5 volts on both wires:
 - H (high) goes to 3.5 volts when active
 - L (low) goes to 1.5 volts when active

Most high-speed BUS systems use resistors at each end, called terminating resistors. Usually, two 120 ohm resistors are installed at each end and are, therefore, connected electrically in parallel. Two 120 ohm resistors connected in parallel measure 60 ohms if tested using an ohmmeter. Figure 14.

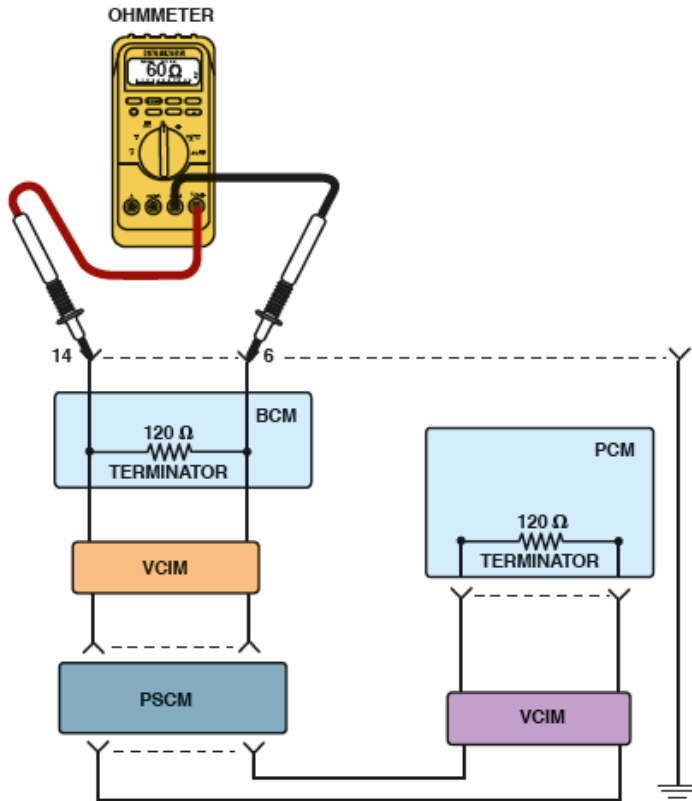

Figure 14. CAN BUS showing the terminating resistors.

A breakout box (BOB) can be used to access the BUS terminals while using a scan tool to activate the modules. The various LEDs flash or come on to indicate circuit status. Figure 15.



Figure 15. This breakout box is equipped with LEDs that light when data circuits are active.

CAN uses a differential type of module communication where the voltage on one wire is the equal, but opposite, voltage on the other wire. When no communication is occurring, both wires have 2.5 volts

applied. When communication is occurring, CAN H goes up 1 to 3.5 volts and CAN L goes down 1 to 1.5 volts. Figure 16.

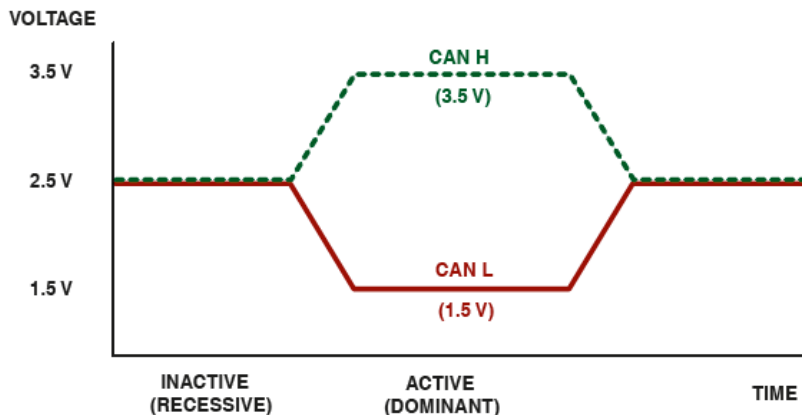

Figure 16. CAN voltage signals.

Using a scope on the data line terminals can show if communication is being transmitted. Typical faults and their causes include the following:

- Normal operation. Normal operation shows variable voltage signals on the data lines.
- High voltage. If there is a constant high-voltage signal without any change, this indicates that the data line is shorted-to-voltage.
- Zero or low voltage. If the data line voltage is zero or almost zero and not showing any higher voltage signals, the data line is short-to-ground.

11. Clear diagnostic trouble codes (DTCs), run all OBD II monitors, and verify the repair.

After the repair has been successfully completed, the vehicle should be driven under similar conditions that caused the original concern to verify that the problem has been corrected. By driving under similar conditions, the PCM may perform a test of the system and automatically extinguish the MIL. This is the method preferred by most vehicle manufacturers.

The DTC can be cleared using a scan tool but then that means that monitors will have to be run, and the vehicle may fail an emissions inspection if driven directly to the testing station.

If the battery has been disconnected or codes cleared with a scan tool, then the vehicle may have to be driven under conditions that allow the PCM to conduct monitor tests. This drive pattern is called a drive cycle. The drive cycle is different for each vehicle manufacturer, but a universal drive cycle may work in many cases. In many cases, performing a universal drive cycle will reset most monitors in most vehicles.

Universal Drive Cycle

A Preconditioning: Phase I.

- MIL must be off.
- No DTCs present.

A8- E. Computerized Engine Controls Diagnosis and Repair

- Fuel fill between 15% and 85%.
- Cold start – Preferred = eight – hour soak at 68°F to 86°F.
- Alternative = ECT below 86°F.

1. With the ignition off, connect scan tool.
2. Start engine and drive between 20 and 30 mph for 22 minutes, allowing speed to vary.
3. Stop and idle for 40 seconds, gradually accelerate to 55 mph.
4. Maintain 55 mph for 4 minutes using a steady throttle input.
5. Stop and idle for 30 seconds, then accelerate to 30 mph.
6. Maintain 30 mph for 12 minutes.
7. Repeat steps 4 and 5 four times.

Using scan tool, check readiness. If insufficient readiness set, continue to universal drive cycle Phase II.

Important: (Do not shut off engine between phases).

Phase II:

1. Bring the vehicle to a stop and idle for 45 seconds, then accelerate to 30 mph.
2. Maintain 30 mph for 22 minutes.
3. Repeat steps 1 and 2 three times.
4. Bring the vehicle to a stop and idle for 45 seconds, then accelerate to 35 mph.
5. Maintain speed between 30 and 35 mph for 4 minutes.
6. Bring the vehicle to a stop and idle for 45 seconds, then accelerate to 30 mph.
7. Maintain 30 mph for 22 minutes.
8. Repeat steps 6 and 7 five times.
9. Using scan tool, check readiness.