

## INTRODUCTION

Entering the engine combustion chamber is fuel (HC) plus air (nitrogen  $N_2$  is 78% and oxygen  $O_2$  is 21% of the air). During combustion, the HC combines with the air to form water  $H_2O$ , carbon dioxide  $CO_2$  plus nitrogen  $N_2$  and some other non-desirable gases.

Some of the other gases include the following:

Unburned hydrocarbons (HC)—If perfect combustion occurs inside the engine, there should not be any left-over unburned fuel.

Carbon monoxide (CO)—During combustion, all the carbon in the fuel should be converted to  $CO_2$  if there is enough oxygen available. If there is not enough oxygen available in the combustion chamber, incomplete combustion occurs, creating CO instead of  $CO_2$ .

Oxides of Nitrogen  $NO_x$  —Nitrogen is 78% of the air, so having some leftover is normal; however, if the combustion temperatures and pressures are high enough, some of the  $N_2$  combines with the oxygen to form NO and  $NO_2$ , which are harmful exhaust gases and referred to as oxides of nitrogen ( $NO_x$ , where the “x” represents the number of oxygen molecules).

Vehicle emission control systems are used to help reduce these emissions:

- HC (unburned hydrocarbons). Excessive HC emissions (unburned fuel) are controlled by the evaporative system (charcoal canister), the positive crankcase ventilation (PCV) system, the secondary air-injection (SAI) system, and the catalytic converter.
- CO (carbon monoxide). Excessive CO emissions are controlled by the positive crankcase ventilation (PCV) system, the secondary air-injection (SAI) system, and the catalytic converter.
- $NO_x$  (oxides of nitrogen). Excessive  $NO_x$  emissions are controlled by the exhaust gas recirculation (EGR) system and the catalytic converter.

## ASE TEST TOPICS

### D-1. Positive Crankcase Ventilation

#### 1. Test and diagnose emissions or driveability problems caused by faults in the positive crankcase ventilation (PCV) system.

Positive crankcase ventilation (PCV) systems were developed to ventilate the crankcase and recirculate the vapors to the engine’s induction system so they can be burned in the cylinders. PCV systems help reduce HC and CO emissions. The PCV valve in most systems is a one-way valve containing a spring operated plunger that controls valve flow rate. Engine design includes the air and vapor flow as a calibrated part of the air-fuel mixture. A valve for a different engine should not be substituted. Figure 1.

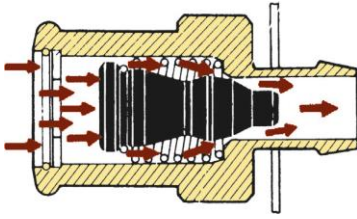

Figure 1. PCV valve, engine idling.

A blocked or plugged PCV system may cause the following to occur:

- Rough or unstable idle
- Excessive oil consumption
- Oil in the air filter housing
- Oil leaks due to excessive crankcase pressure

**2. Inspect, test, service, repair, and replace positive crankcase ventilation (PCV) filter, valve, oil separator, orifice/metering device, and hoses.**

A properly operating PCV system should be able to draw vapors from the crankcase and into the intake manifold. If the pipes, hoses, and PCV valve itself are not restricted, vacuum is applied to the crankcase. The PCV system can be checked by testing for a weak vacuum at the oil dipstick tube using an inches-of-water manometer or gauge. Figure 2.

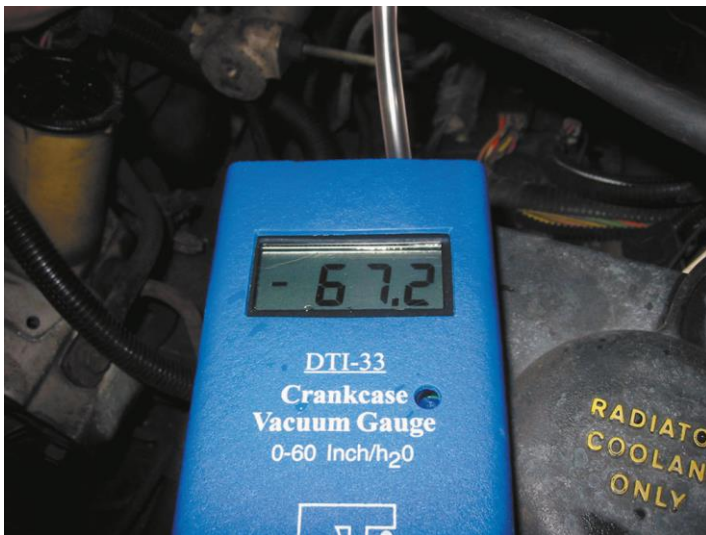

Figure 2. Using a gauge that measures vacuum in units of inches of water. (28 inches H<sub>2</sub>O = 1 PSI).

Turbocharged and many fuel-injected engines use an oil/vapor or oil/water separator and a calibrated orifice instead of a PCV valve. In the most common applications, the air intake throttle body acts as the source for crankcase ventilation vacuum, and a calibrated orifice acts as the metering device. The separator can become clogged, causing high crankcase pressure and oil leaks. Figure 3.

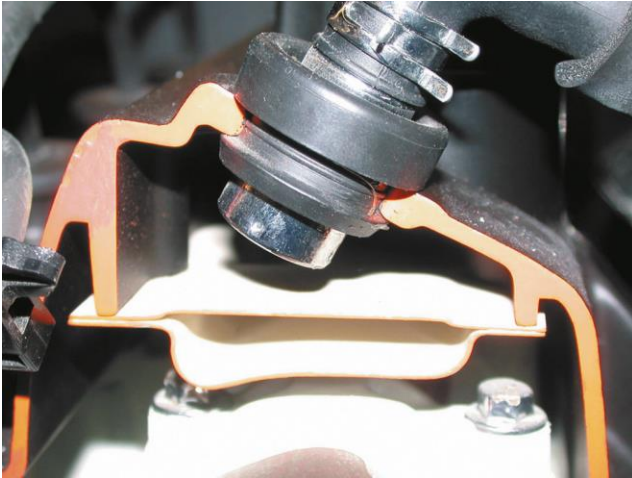

Figure 3. The oil separator should be checked during service.

Starting with 2004 and newer vehicles, all vehicle PCMs monitor the PCV system for proper operation as part of the OBD-II system. The PCV monitor will fail if the PCM detects an opening between the crankcase and the PCV valve or between the PCV valve and the intake manifold.

## D-2. Exhaust Gas Recirculation

### 1. Test and diagnose driveability problems caused by faults in the exhaust gas recirculation (EGR) system.

To handle the NO<sub>x</sub> generated above 2,500°F (1,370°C), the most efficient method to meet NO<sub>x</sub> emissions without significantly affecting engine performance, fuel economy, and other exhaust emissions is to use exhaust gas recirculation (EGR). The EGR system routes small quantities, usually between 6% and 10%, of exhaust gas into the intake manifold. Figure 4.

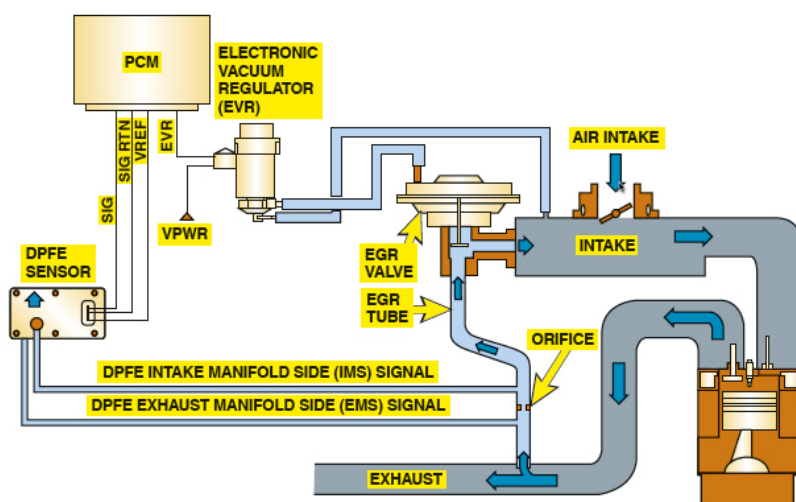

Figure 4. EGR system.

If the EGR valve is not opening or the flow of the exhaust gas is restricted, then the following symptoms are likely:

- Detonation (spark knock or ping) during acceleration or during cruise (steady-speed driving)
- Excessive oxides of nitrogen (NO<sub>x</sub>) exhaust emissions

If the EGR valve is stuck open or partially open, then the following symptoms are likely:

- Rough idle or frequent stalling
- Poor performance/low power, especially at low engine speed

## 2. Interpret exhaust gas recirculation (EGR)-related scan tool data and diagnostic trouble codes (DTCs); determine needed action.

The OBD-II system performs a test by opening and closing the EGR valve. The PCM monitors either the oxygen or MAP sensor for a change in signal voltage. If the EGR system fails, a DTC is set. If the system fails two consecutive times, the MIL is lit. Figure 5.

DIAGNOSTIC TROUBLE CODE	DESCRIPTION	POSSIBLE CAUSES
P0400	Exhaust gas recirculation flow problems	<ul style="list-style-type: none"> <li>• EGR valve</li> <li>• EGR valve hose or electrical connection</li> <li>• Defective PCM</li> </ul>
P0401	Exhaust gas recirculation flow insufficient	<ul style="list-style-type: none"> <li>• EGR valve</li> <li>• Clogged EGR ports or passages</li> </ul>
P0402	Exhaust gas recirculation flow excessive	<ul style="list-style-type: none"> <li>• Stuck-open EGR valve</li> <li>• Vacuum hose(s) misrouted</li> <li>• Electrical wiring shorted</li> </ul>

Figure 5. EGR system possible DTCs.

## 3. Inspect, test, service, repair, and replace components of the exhaust gas recirculation (EGR) system, including EGR valve, tubing, passages, vacuum/pressure controls, filters, hoses, coolers, electrical/ electronic sensors, controls, solenoids and wiring.

The EGR system recycles some exhaust gas back into the intake stream to cool combustion, which reduces oxides of nitrogen (NO<sub>x</sub>) emissions. The EGR system includes:

- Plumbing that carries some exhaust gas from the exhaust manifold to the intake ports
- EGR control valve
- Stainless steel cooling element used to cool the exhaust gases (some vehicles)

Many vehicles use a linear EGR valve that contains a pulse-width modulated solenoid to precisely regulate exhaust gas flow and a feedback potentiometer that signals the PCM regarding the actual position of the valve. Figure 6.

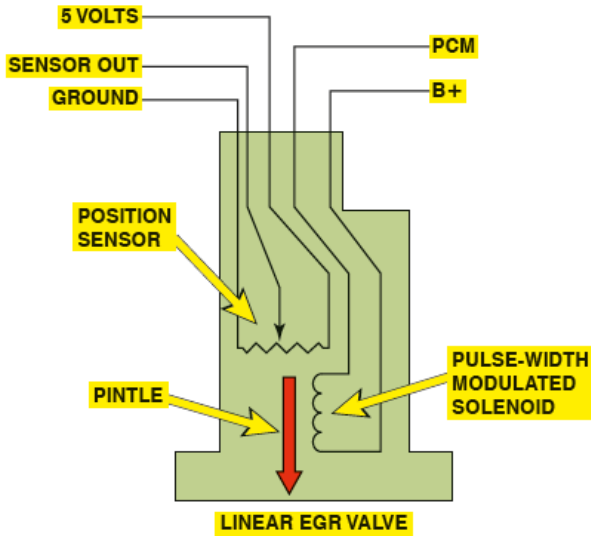

Figure 6. Electrical components of a linear EGR valve.

### D-3. Secondary Air Injection (AIR) and Catalytic Converter

#### 1. Test and diagnose emissions or driveability problems caused by faults in the secondary air injection or catalytic converter systems.

The secondary air-injection (SAI) system provides the air necessary for the oxidizing process either at the exhaust manifold or inside the catalytic converter. The air pump system should be inspected if an exhaust emissions test failure occurs.

The tap test involves tapping (not pounding) on the catalytic converter using a rubber mallet. If the substrate inside the converter is broken, the converter will rattle when hit. If the converter rattles, a replacement converter is required. Figure 7.

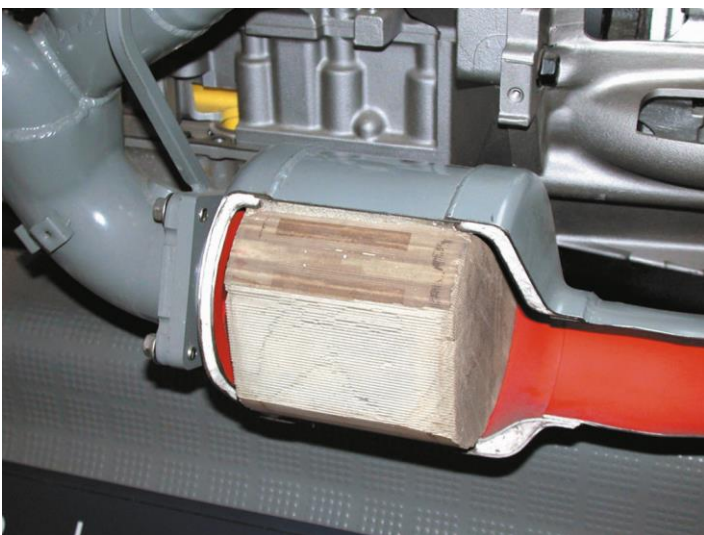

Figure 7. The catalytic converter substrate is a hard ceramic than can break apart if impacted.

Exhaust system backpressure can be measured directly by installing a pressure gauge in an exhaust opening. An exhaust restriction can be tested indirectly by checking the intake manifold vacuum with the engine operating at a fast idle speed (about 2,500 RPM).

**2. Interpret secondary air injection system-related scan tool data and diagnostic trouble codes (DTCs); determine needed action.**

The SAI pump solenoids are controlled by the PCM. The PCM turns on the SAI pump by providing the ground to complete the circuit which energizes the SAI pump solenoid relay. The PCM turns on the SAI pump during start-up any time the engine coolant temperature is above 32°F (0°C). A typical electric SAI pump operates for a maximum of four minutes, or until the system enters closed-loop operation.

A scan tool can monitor the status of the AIR system (on or off) after the engine is started. The scan tool can also be used to command the air pump ON to check its operation. Figure 8.

DIAGNOSTIC TROUBLE CODE	DESCRIPTION	POSSIBLE CAUSES
P0410	SAI solenoid circuit fault	<ul style="list-style-type: none"> <li>Defective SAI solenoid</li> <li>Loose or corroded electrical connections</li> <li>Loose, missing, or defective rubber hose(s)</li> </ul>

Figure 8. SAI related diagnostic trouble code (DTC).

**3. Inspect, test, service, repair, and replace mechanical components and electrical/electronic components and circuits of secondary air injection systems.**

Carefully inspect all secondary-air-injection (SAI) systems, including:

- Any hoses or pipes that have holes and leak air or exhaust, which require replacement
- Check valve (if accessible)
- On electric AIR systems, listen carefully to hear the pump running upon a cold start and then listen for it to shut off after a few minutes.

**4. Inspect catalytic converter. Interpret catalytic converter-related diagnostic trouble codes (DTCs); analyze related scan tool data to determine root cause of DTCs; determine needed action.**

A catalytic converter is an aftertreatment device used to reduce exhaust emissions outside of the engine. In a three-way catalytic converter (TWC), all three exhaust emissions (NO<sub>x</sub>, HC, and CO) are converted to carbon dioxide CO<sub>2</sub> and water (H<sub>2</sub>O). Figure 9.

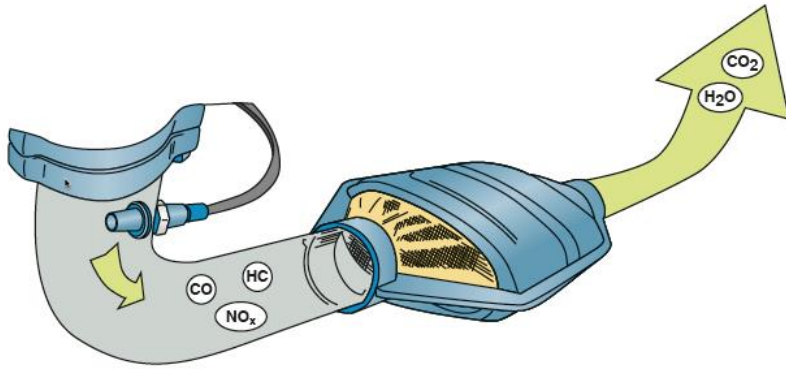

Figure 9. Catalytic converter operation.

With OBD-II equipped vehicles, catalytic converter performance is monitored by a heated oxygen sensor (HO2S), both before and after the converter. Converter performance faults will light the malfunction indicator (MIL) and set DTCs. Figure 10.

DIAGNOSTIC TROUBLE CODE	DESCRIPTION	POSSIBLE CAUSES
P0420	Catalytic converter efficiency failure	<ol style="list-style-type: none"> <li>1. Engine mechanical fault</li> <li>2. Exhaust leaks</li> <li>3. Fuel contaminants, such as engine oil, coolant, or sulfur</li> </ol>

Figure 10. Sample catalytic converter-related DTC.

#### D-4. Evaporative Emissions Controls

##### 1. Test and diagnose emissions or driveability problems caused by faults in the evaporative emissions control system.

The purpose of the evaporative emission control system is to trap and hold gasoline vapors, also called Volatile organic compounds (VOCs). The evaporative control system (EVAP) includes the charcoal canister, hoses, and valves. These vapors are routed into a charcoal canister, then into the intake airflow, where they are burned in the engine, instead of being released into the atmosphere.

All vehicles built after 1995 have enhanced EVAP systems with the ability to detect purge flow and system leakage. If either of these two functions fails, the system is required to set a diagnostic trouble code (DTC) and turn on the malfunction indicator lamp (MIL) to warn the driver of the failure. Figure 11.

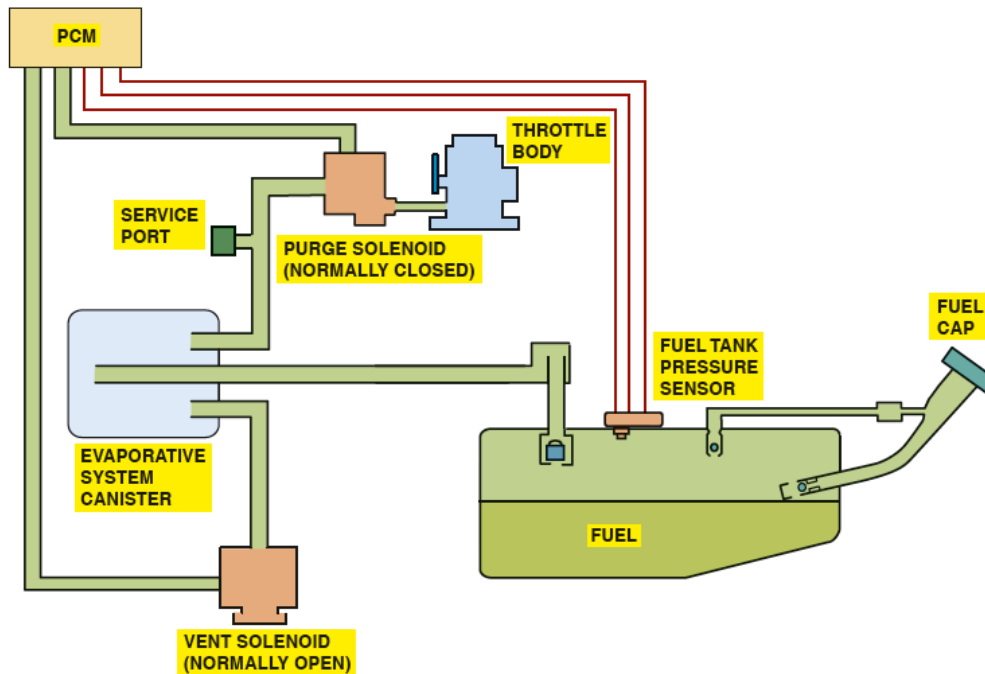

Figure 11. Enhanced EVAP system.

Common engine performance problems that can be caused by a fault in this system include the following:

- Poor performance. A vacuum leak in the system can cause the engine to run rough. Age, heat, and time all contribute to the deterioration of rubber hoses.
- Hard-to-start condition after refueling. If the purge solenoid becomes stuck in the open position, gasoline fumes are allowed to flow directly from the gas tank to the intake manifold. This also results in a rich exhaust, and likely black exhaust, when first starting.
- Failed state emissions test. Enhanced exhaust emissions (I/M-240) testing tests the evaporative emission system for leaks. The system is typically pressurized with nitrogen. The pressure in the system is then shut off and the pressure monitored. If the pressure drops below a set standard, then the vehicle fails the test.

## 2. Interpret evaporative emissions-related scan tool data and diagnostic trouble codes (DTCs); determine needed action.

All OBD-II vehicles perform a canister purge system pressure test, as commanded by the PCM. After two consecutive failed trips testing either purge volume or the presence of a leak, the PCM lights the MIL and sets a DTC. Figure 12.

Diagnostic Trouble Code	Description	Possible Causes
P0440	Evaporative system fault	<ul style="list-style-type: none"> <li>● Loose gas cap</li> <li>● Defective EVAP vent</li> <li>● Cracked charcoal canister</li> <li>● EVAP vent or purge vapor line problems</li> </ul>
P0442	Small leak detected	<ul style="list-style-type: none"> <li>● Loose gas cap</li> <li>● Defective EVAP vent or purge solenoid</li> <li>● EVAP vent or purge line problems</li> </ul>
P0446	EVAP canister vent blocked	<ul style="list-style-type: none"> <li>● EVAP vent or purge solenoid electrical problems</li> <li>● Restricted EVAP canister vent line</li> </ul>

Figure 12. EVAP system DTCs.

### 3. Inspect, test, service, repair, and replace canister, lines/hoses, filters, mechanical and electrical components of the evaporative emissions control system.

**Leaks.** Leaks in the evaporative emission control system cause the malfunction check gas cap indication lamp to light on some vehicles. A leak also causes a gas smell, which is most noticeable if the vehicle is parked in an enclosed garage. The most efficient method of leak detection is to introduce smoke under low pressure from a machine specifically designed for this purpose. Figure 13.



Figure 13. Smoke testing shows that the gas cap seal is leaking.

**Control solenoids.** The purge and vent solenoids can be tested using a scan tool to command them on and off. The vent solenoid is located under the vehicle, in most cases, and is exposed to the environment, making this valve subject to rust and corrosion.

Fuel tank pressure sensor. The fuel tank pressure (FTP) sensor is similar to a MAP sensor, and instead of monitoring intake manifold absolute pressure, it is used to monitor fuel tank pressure. Replacing a defective sensor requires dropping the fuel tank. Figure 14.



Figure 14. The FTP sensor is often part of the fuel pump module.