

Name _____

MULTIPLE CHOICE. Choose the one alternative that best completes the statement or answers the question.

- 1) Evaporative emission control systems operate on low pressure measured in inches of water. One psi is equal to how many inches of water? 1) _____
A) 1
B) 10
C) 18
D) 28
- 2) Which EVAP valve is subject to rust and corrosion more than all of the others? 2) _____
A) Purge valve
B) Vacuum control valve
C) Vent valve
D) Roll over check valve
- 3) A vehicle failed an emission test due to high carbon monoxide and hydrocarbons in the exhaust gas. What could be the cause? 3) _____
A) Saturated EVAP charcoal canister
B) Overfilling the fuel tank
C) Either A or B
D) Neither A nor B
- 4) Which of these components is the EVAP system purge solenoid? 4) _____

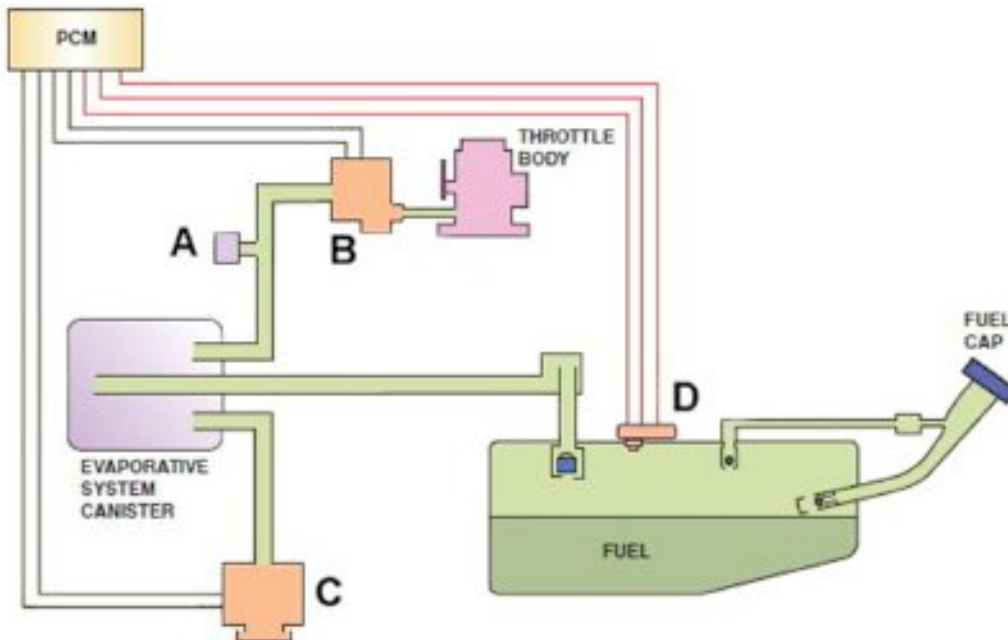

- A) A
B) B
C) C
D) D

- 5) The canister vent valve is a normally _____ valve. 5) _____
A) open
B) closed
C) pulsed
D) omitted on some vehicles
- 6) Inadequate purge flow rate will trigger which DTC? 6) _____
A) P0440
B) P0446
C) P0300
D) P0440 or P0446
- 7) What is the substance used in a vapor canister to absorb volatile organic compounds? 7) _____
A) Desiccant
B) Organic absorber
C) Pleated paper
D) Carbon
- 8) Technician A says that fuel filler caps with pressure and vacuum vents are used with EVAP system fuel tanks. Technician B says that using a non-vented cap on a system equipped with an evaporative emissions system may cause damage to the fuel tank. Which technician is correct? 8) _____
A) Technician A only
B) Technician B only
C) Both technicians
D) Neither technician
- 9) Two technicians are discussing a state emission test. Technician A says that a vent valve that is not able to close can cause the system to fail the on-board test. Technician B says that a leaking gas cap can cause a failure of the EVAP test. Which technician is correct? 9) _____
A) Technician A only
B) Technician B only
C) Both technicians
D) Neither technician
- 10) A small leak is detected by the evaporative emission control system monitor that could be caused by a loose gas cap. Which DTC will likely be set? 10) _____
A) P0440
B) P0442
C) P0446
D) P0440, P0441, or P0442