

Name _____

MULTIPLE CHOICE. Choose the one alternative that best completes the statement or answers the question.

1) When the ignition is first turned on a click noise is heard from under the hood of a vehicle equipped with ETC. Technician A says that this is the normal operation of the ETC self-test. Technician B says that the ETC motor should not move unless the engine is running. Which technician is correct? 1) _____

- A) Technician A only
- B) Technician B only
- C) Both technicians
- D) Neither technician

2) Identify the throttle position sensor assembly in this diagram. 2) _____

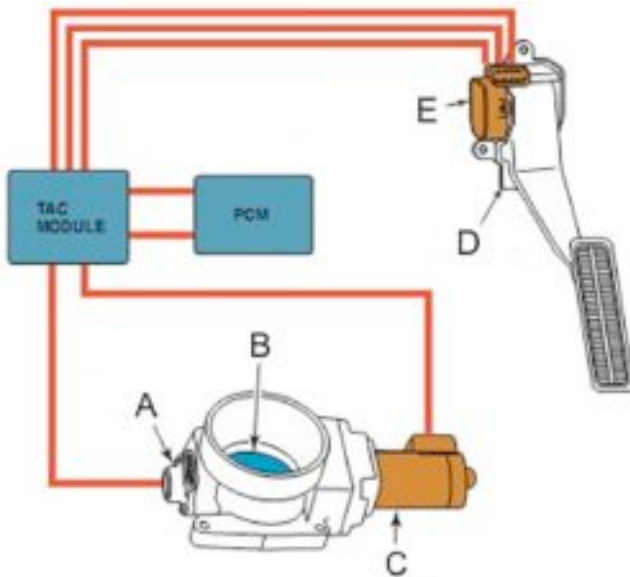

- A) A
- B) C
- C) D
- D) E

3) Which component in this photograph is the drive (motor) gear?

3) _____



- A) A
- B) B
- C) C
- D) D

4) The throttle plate actuator motor is what type of electric motor?

4) _____

- A) Stepper motor
- B) DC motor
- C) AC motor
- D) Brushless motor

5) With the ignition off and the key out of the ignition, what should happen if a technician uses a screwdriver to gently push on the throttle plate in an attempt to open the valve?

5) _____

- A) Nothing. The throttle should be kept from moving by the motor, which is not energized with the key off.
- B) The throttle should move and stay where it is moved and not go back unless moved back.
- C) The throttle should move, and then spring back to the home position when released.
- D) The throttle should move closed, but not open further than the default position.

6) The throttle body may be cleaned (if recommended by the vehicle manufacturer) if what conditions are occurring?

6) _____

- A) Coast-down stall
- B) Rough idle
- C) Lower-than-normal idle speed
- D) Any of the above

7) The accelerator pedal position sensor uses _____ sensor(s), which acts to give accurate accelerator pedal position information to the controller.

7) _____

- A) more than three
- B) two or three
- C) one
- D) a vacuum

8) The accelerator position sensor outputs 2 identical, redundant voltage signals. 8) _____
A) True
B) False

9) The ETC actuator motor is controlled by the PCM through what type of circuit? 9) _____
A) Series
B) Parallel
C) H-bridge
D) Series-Parallel

10) In this diagram, which terminals are used for the TP sensors? 10) _____

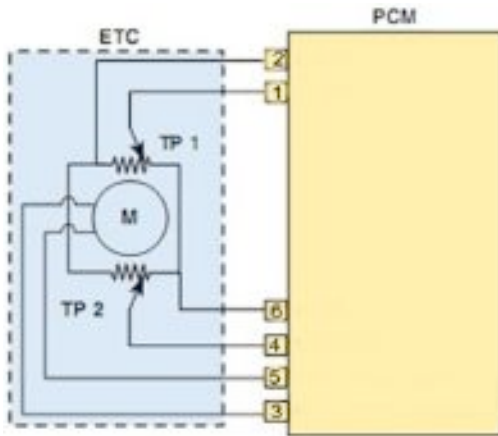

- A) 1, 2, 4, 6
- B) 1, 2, 3, 4
- C) 3, 5, 4, 6
- D) 3, 5