

Diesel Engine Management System

This electronic diesel engine management system significantly increases fuel combustion efficiency by highly pressurizing diesel fuel and using a feedback injection control system, leading to lower fuel consumption and exhaust emissions.

Key Points

- DENSO's advanced technology increases fuel efficiency while reducing exhaust emissions
- Ultra-high-pressure (2,500bar) fuel injection system finely atomizes fuel
- Feedback injection control system (i-ART[®]) for stable combustion

System Structure

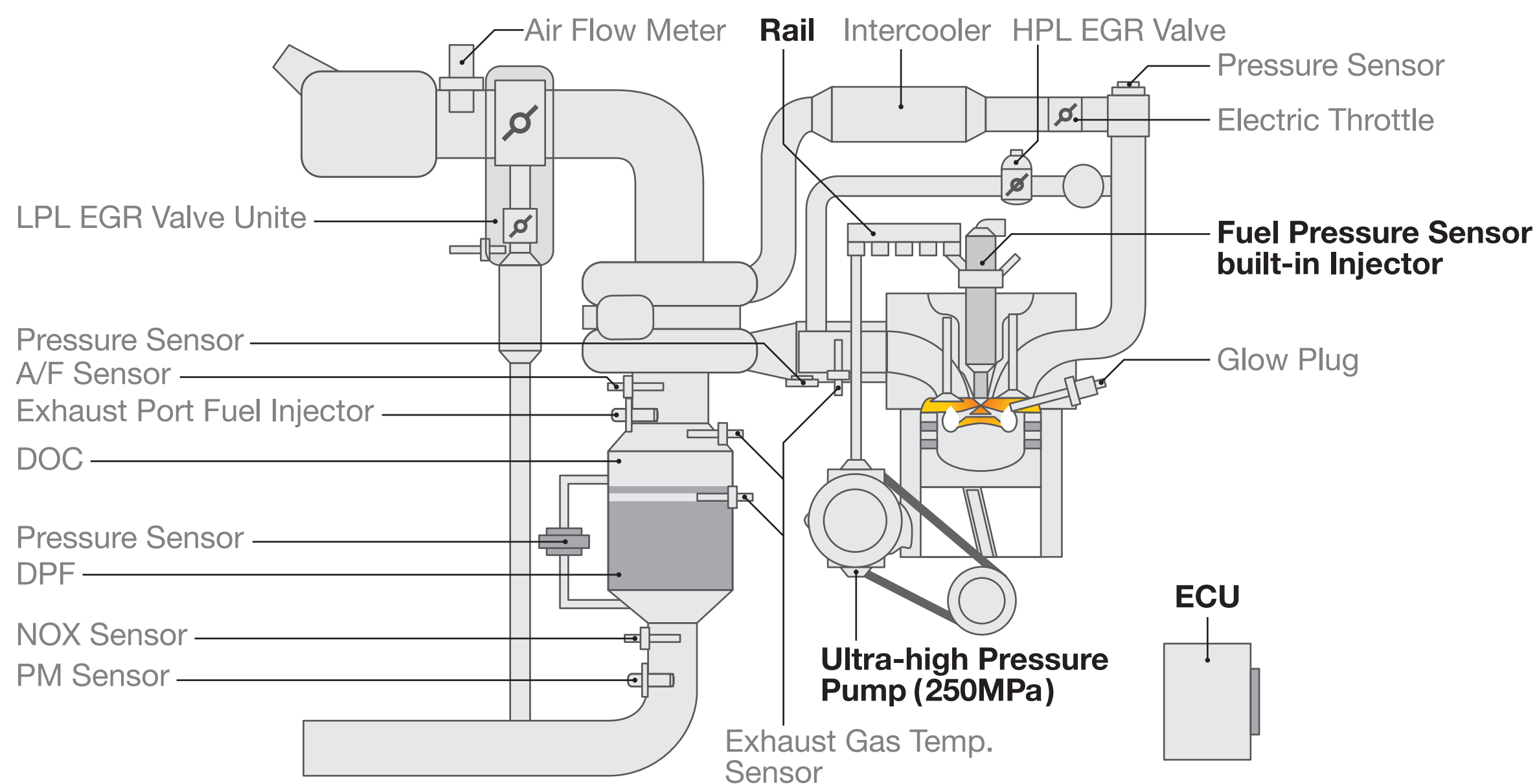

Feedback Injection Control System

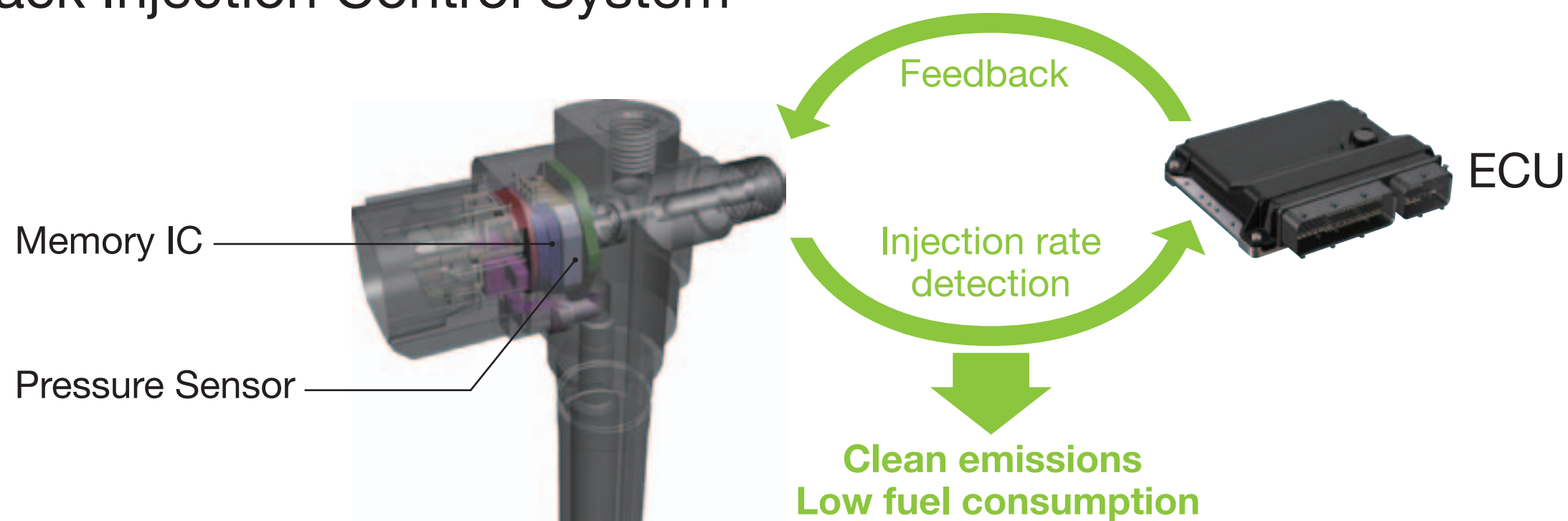

Diesel Engine Management System

DENSO offers fuel injection system for simple and reasonable diesel engine management system to combine clean emissions and low fuel consumption.

■ Feature

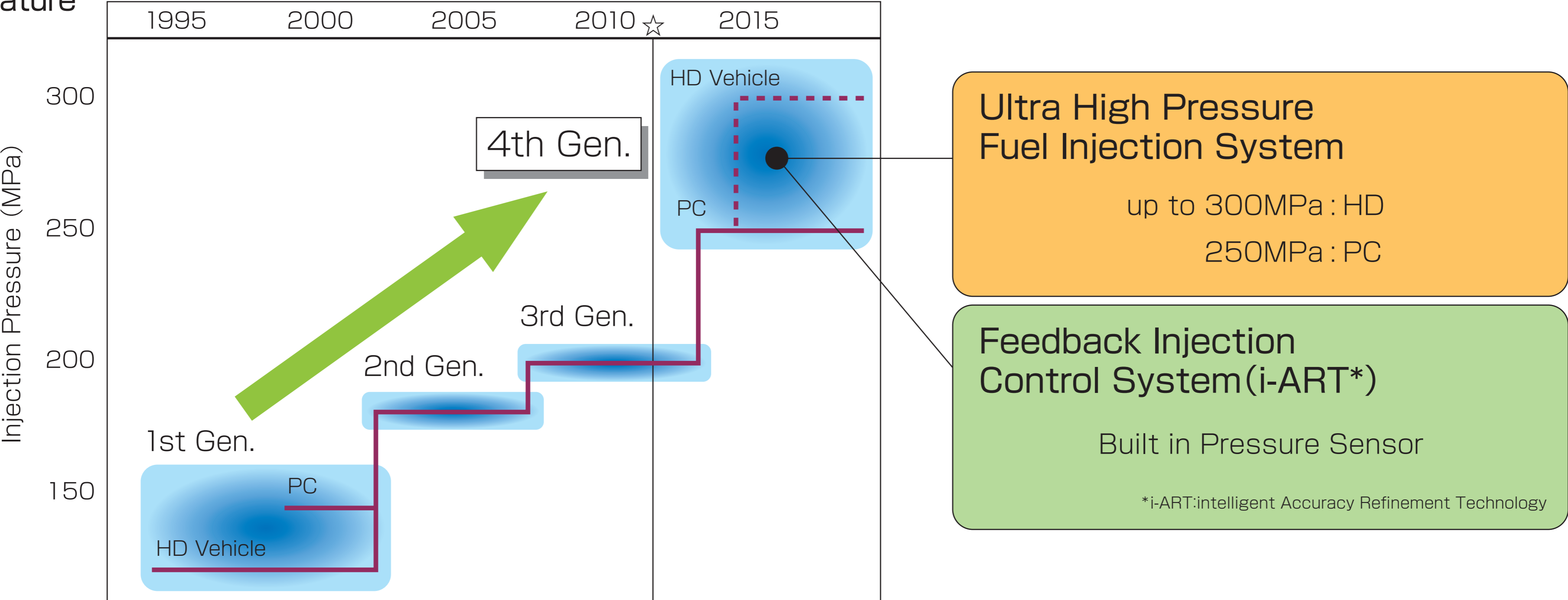

Diesel Engine Management System

■ Engineering Key Point

Ultra High Pressure Fuel Injection System

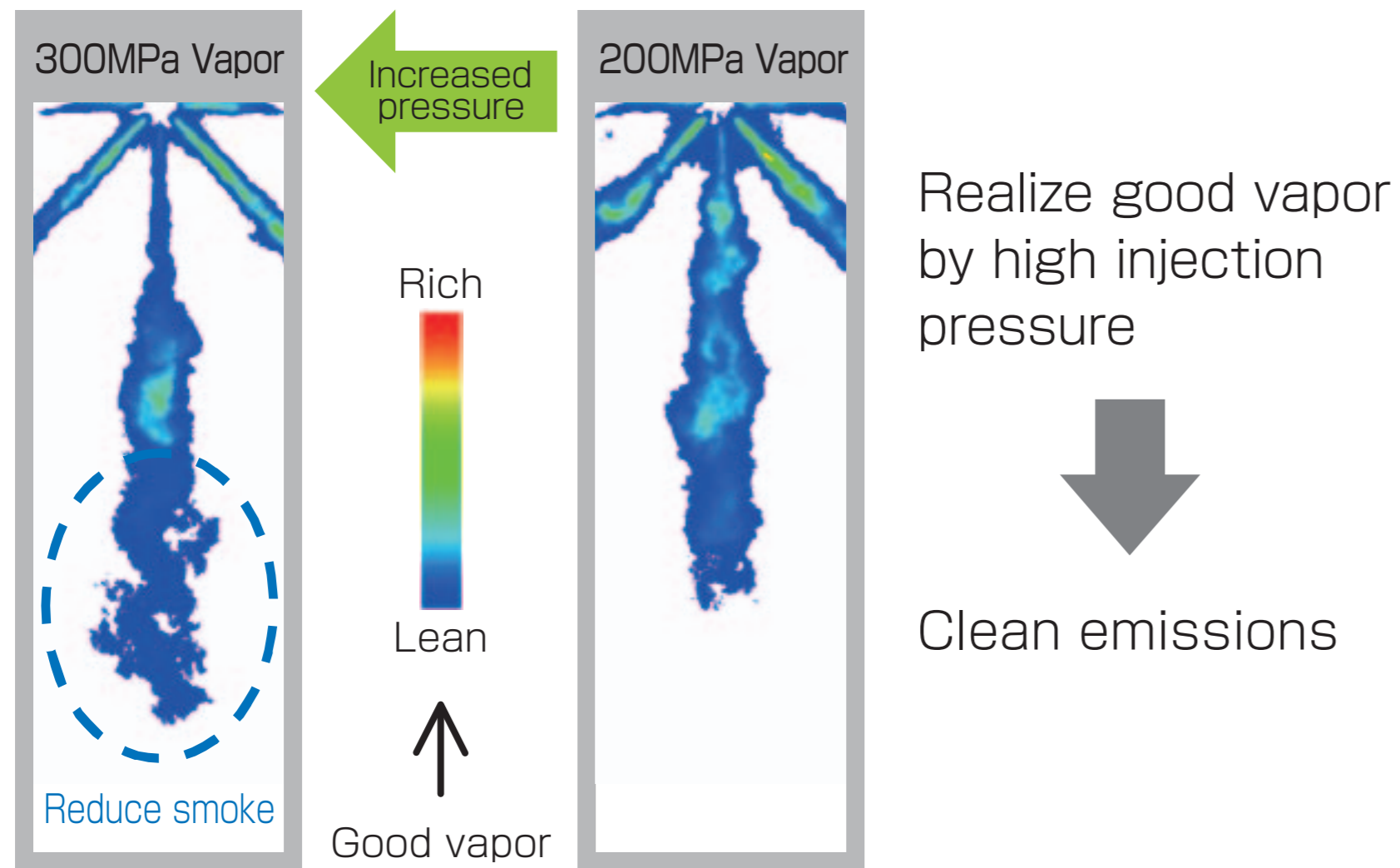

Feedback Injection Control System

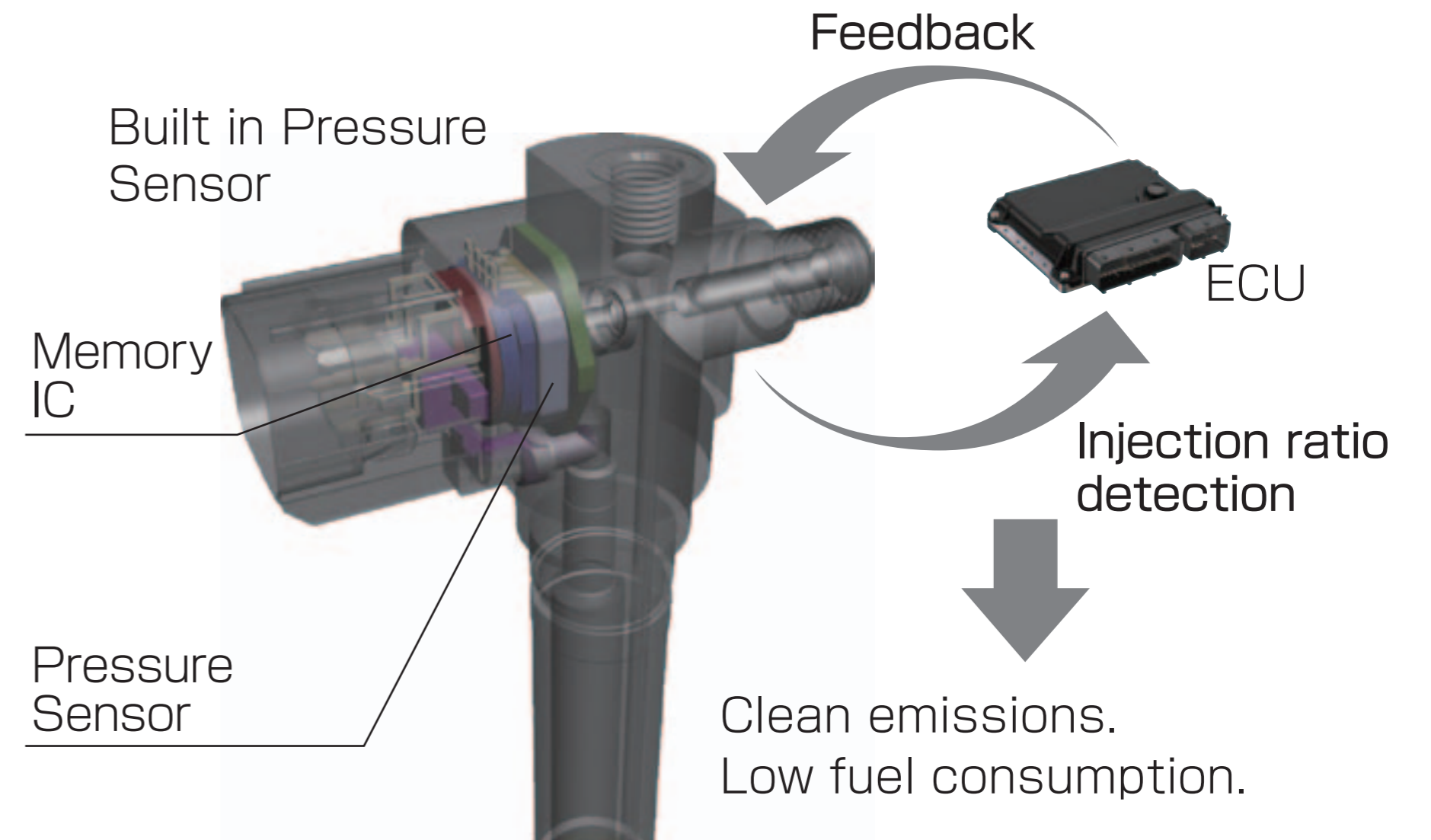

Diesel Engine Management System

Benefit

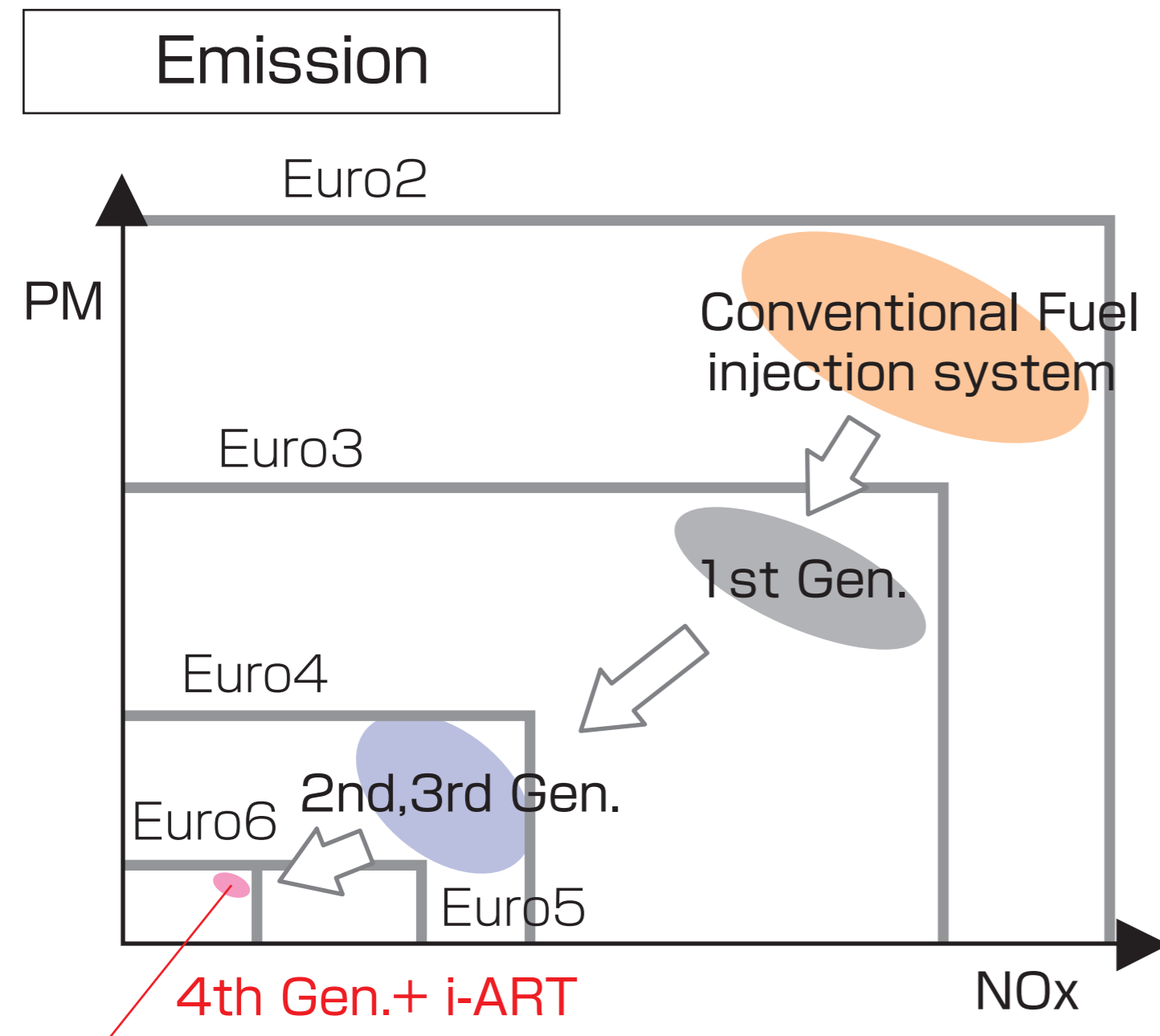

Realize clean emissions.

Fuel consumption

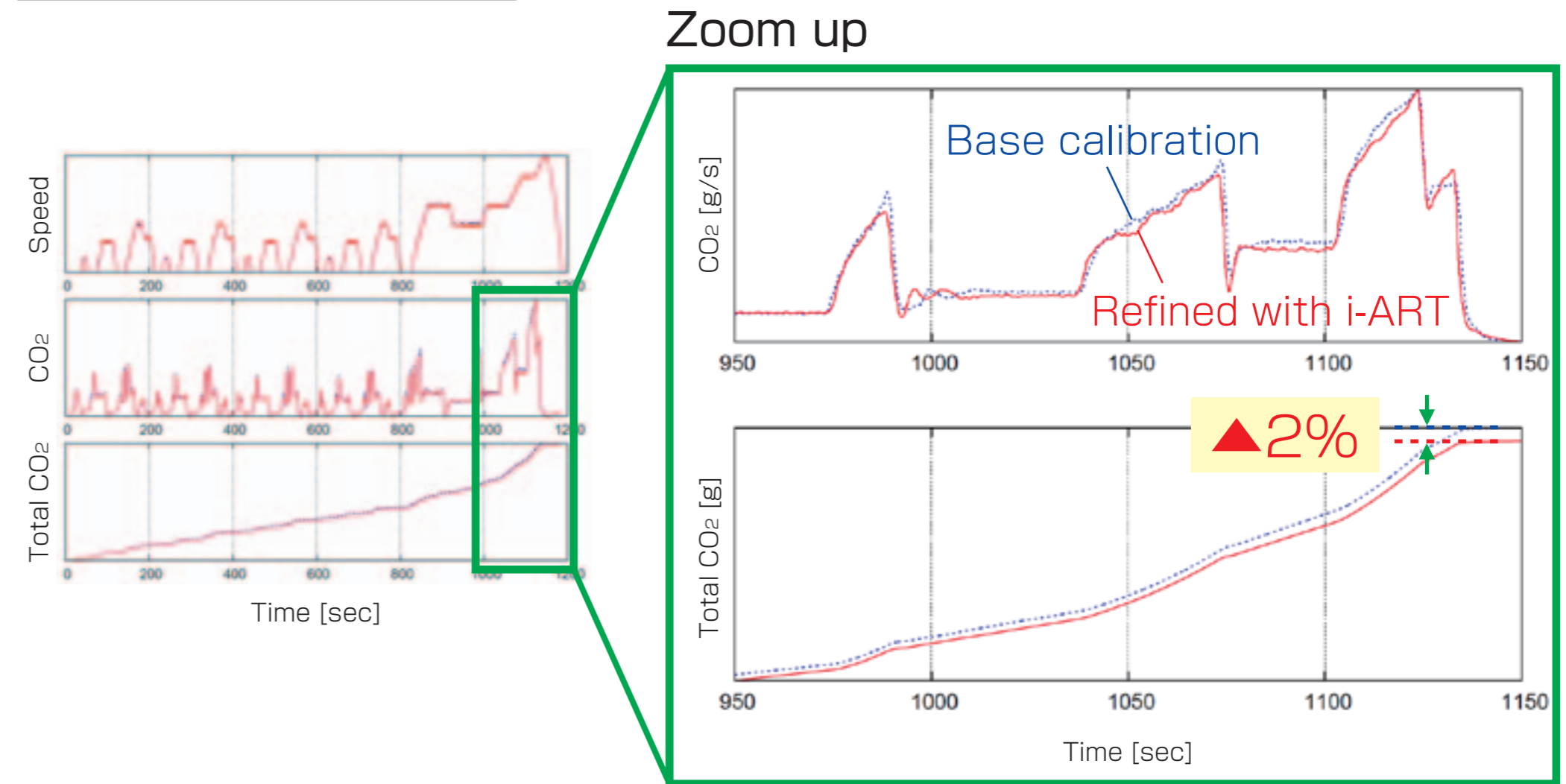

Reduce CO₂ by 2% on driving cycle

Diesel Engine Management System

Press the button to see your selected product.

Accelerator Pedal Module

Cam Position Sensor
Crank Position Sensor

Coolant Temperature
Sensor

Air Flow Meter

Ceramic Glow Plug

Electronic Throttle Body

Air-Fuel Ratio Sensor

Common Rail

Engine
Electronic Control Unit

Diesel Engine Management System

Press the button to see your selected product.

Exhaust Gas
Pressure Sensor

Exhaust Gas
Temperature Sensor

Intercooler

Exhaust Gas
Recirculation Cooler

Exhaust Port Fuel Injector

Pre-Turbo Exhaust Gas
Pressure Sensor

Exhaust Gas
Recirculation Valve

Fuel Filter

Solenoid Injector
for i-ART[®] system

Diesel Engine Management System

Press the button to see your selected product.

A rectangular button with rounded corners, a light gray gradient, and a dark gray vertical bar on the left side. The text "Turbo Pressure Sensor" is centered to the right of the bar.

Turbo Pressure Sensor

A rectangular button with rounded corners, a light gray gradient, and a dark gray vertical bar on the left side. The text "Ultra-high-pressure pump" is centered to the right of the bar.

Ultra-high-pressure pump

Accelerator Pedal Module

An accelerator pedal module detects the amount of pedal depression, which is basic information to control the fuel injection quantity, while providing good pedal operation feel.

- Contactless Hall IC sensor for a longer life and higher reliability
 - Swash-plate pedal pressure-induced hysteresis mechanism for good pedal operation feel
 - Resin components for lighter weight and lower costs
-

Accelerator Pedal Module

Operating principle of a Hall IC sensor

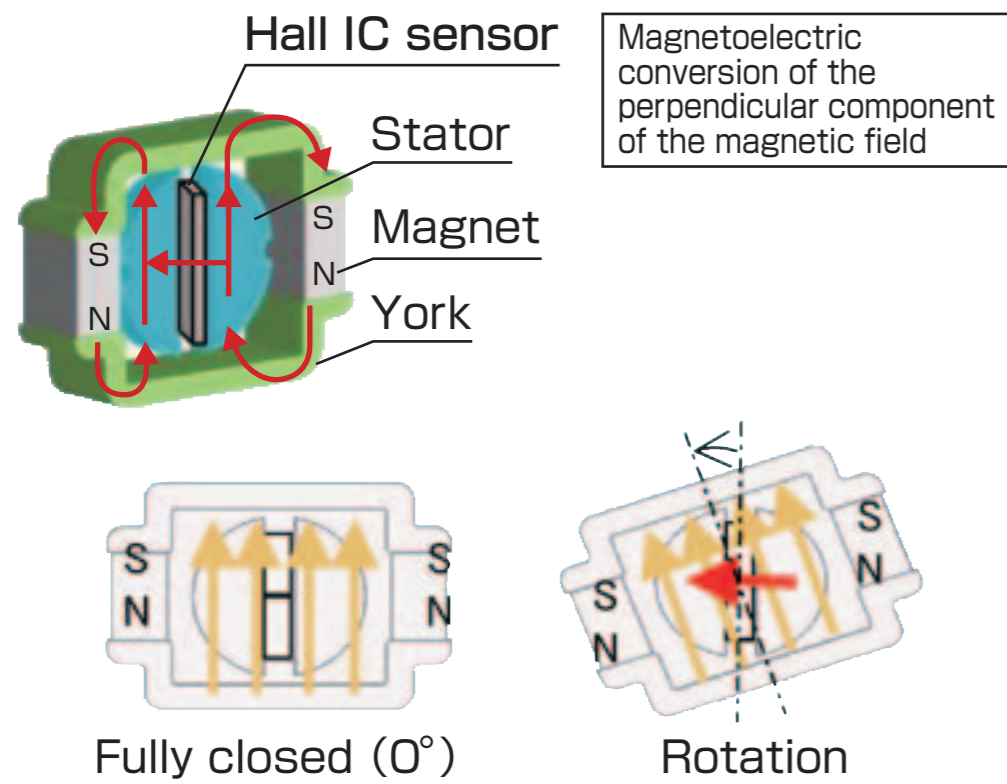
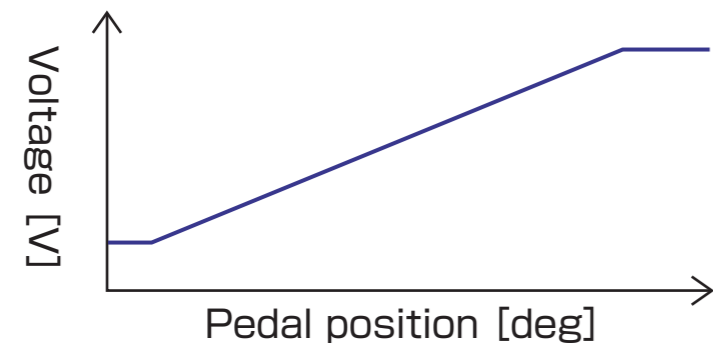

The magnetic flux that changes according to the pedal position is converted into a voltage

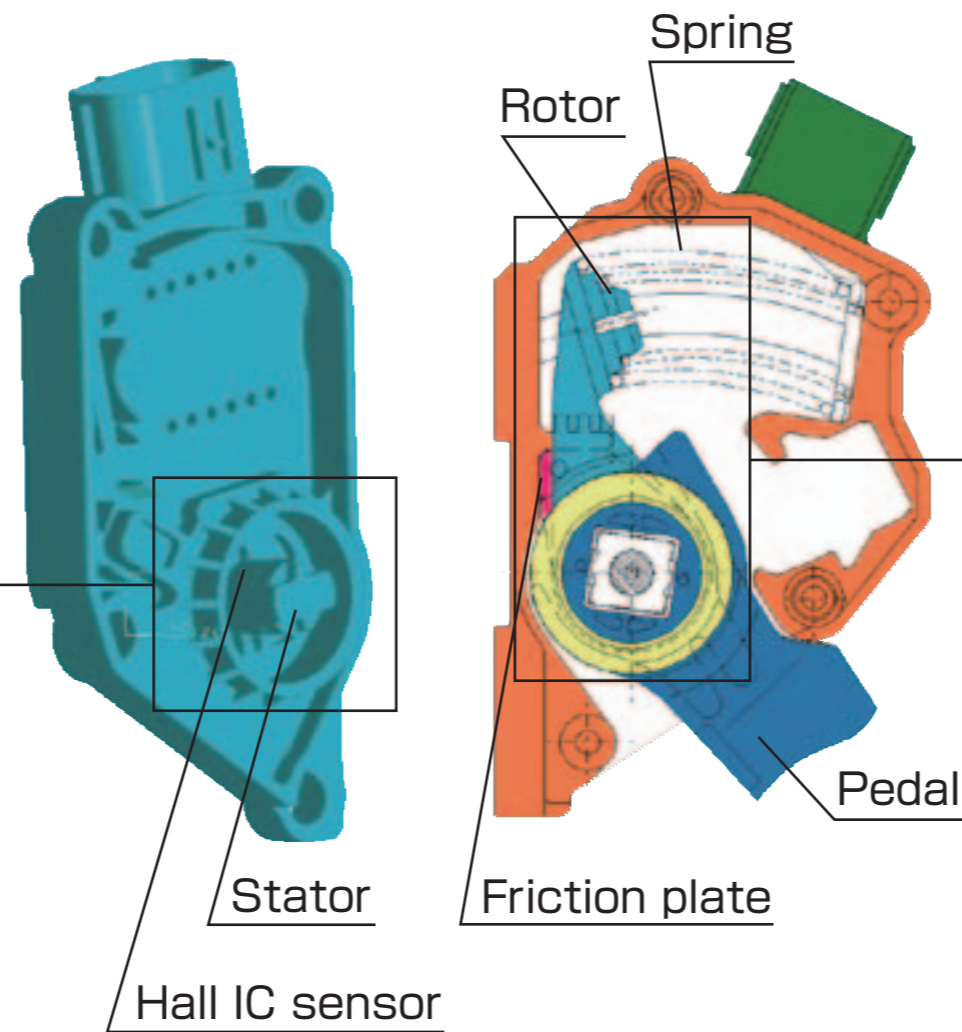

Swash-plate pedal pressure-induced hysteresis mechanism

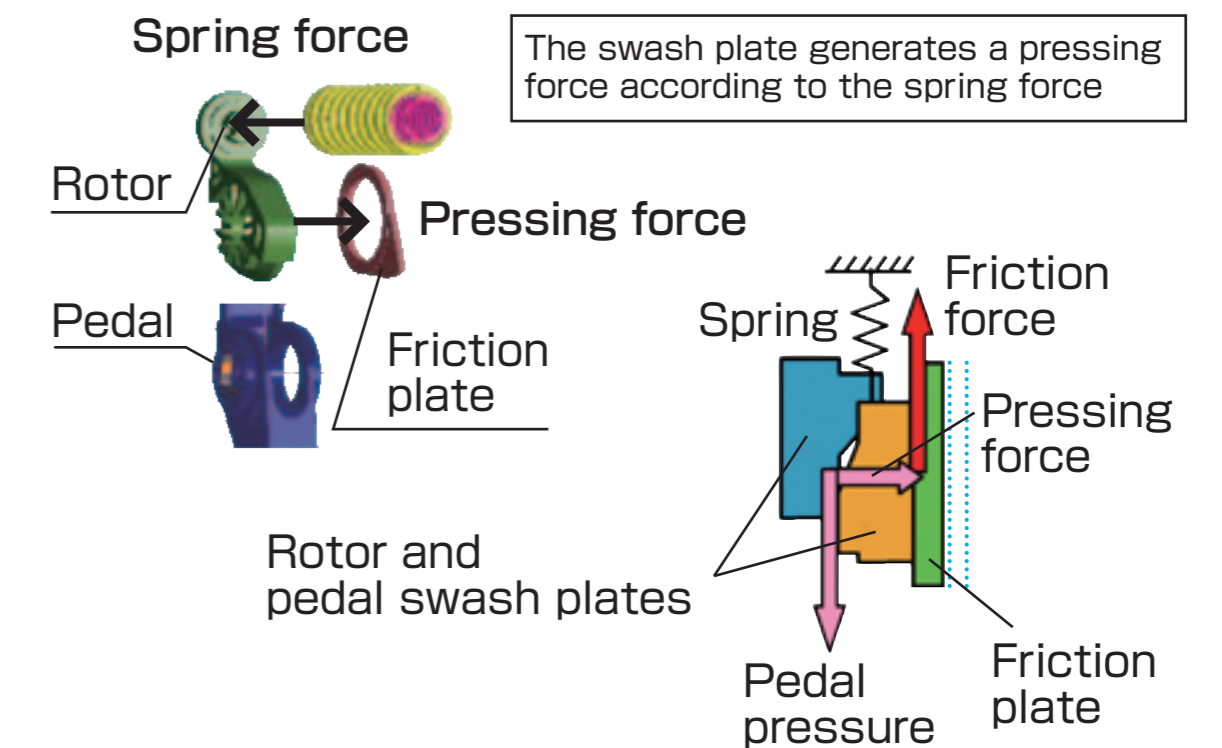
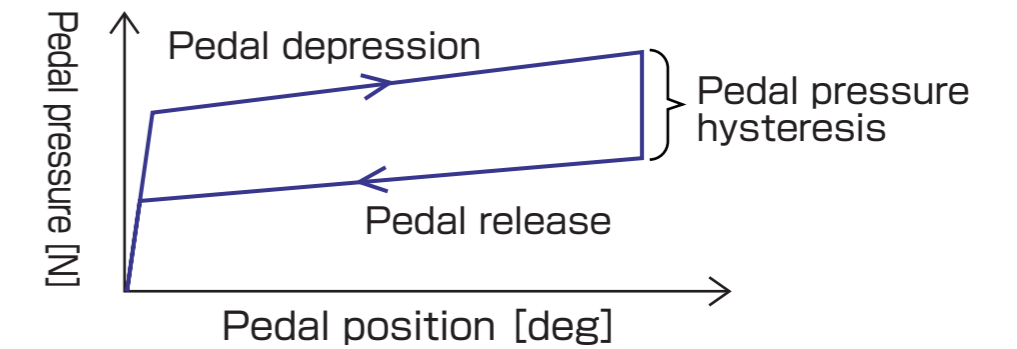

The pressing force generated by the swash plates produces a friction force (pedal pressure hysteresis)

Air Flow Meter

Meter to measure the amount of air taken into the engine to optimally control the amount of exhaust gas recirculation (EGR) that influences diesel engine power, emissions, and fuel efficiency.

- Air flow meter-specific IC for a smaller circuit chamber
- New air flow bypass with air intake apertures allowing for more precise measurements when a pulsating flow arises and for expanded measuring range

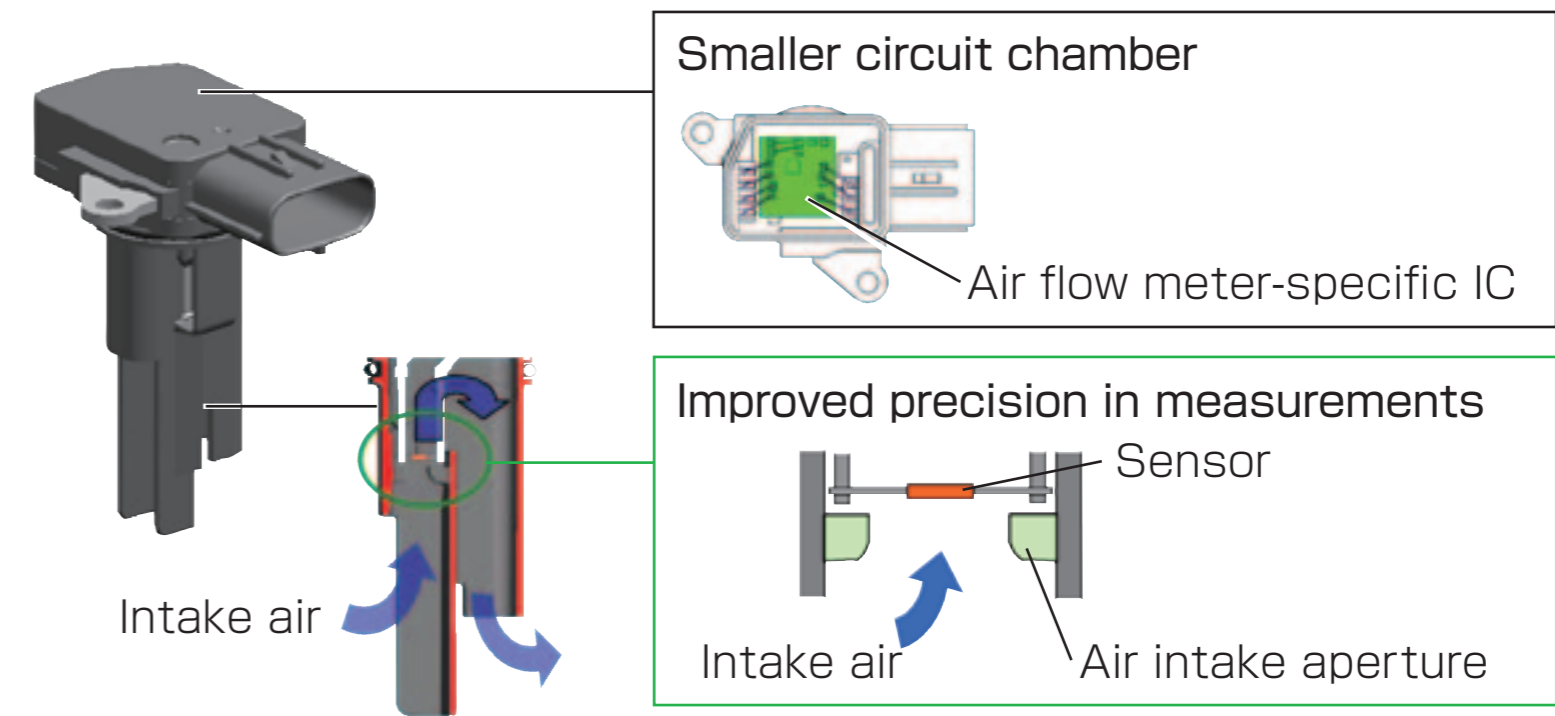

Effects

Installed on the air cleaner; Durability: 10 years or 160,000 km

	Conventional product	This product
Weight (g)	52	31 (▲40%)
Measurement precision when a pulsating flow arises (%)	±8.0	±5.0 (▲40%)
Measurement range (maximum air flow/minimum air flow)	106 times	140 times

Air-Fuel Ratio Sensor

A quick activation type air-fuel ratio sensor is designed to achieve low emissions.

- The sensor detects a broad range of air-fuel ratio in emissions (from lean to rich)
- The sensor can be activated quickly when the engine is started using a compact element with a built-in heater
- The sensor can be used over a broad range of emission temperatures (250~1,000°C)
- The sensor features excellent water resistance and air tightness

Air-fuel ratio : mass ratio of air to fuel

■ Overall structure of an air-fuel ratio sensor

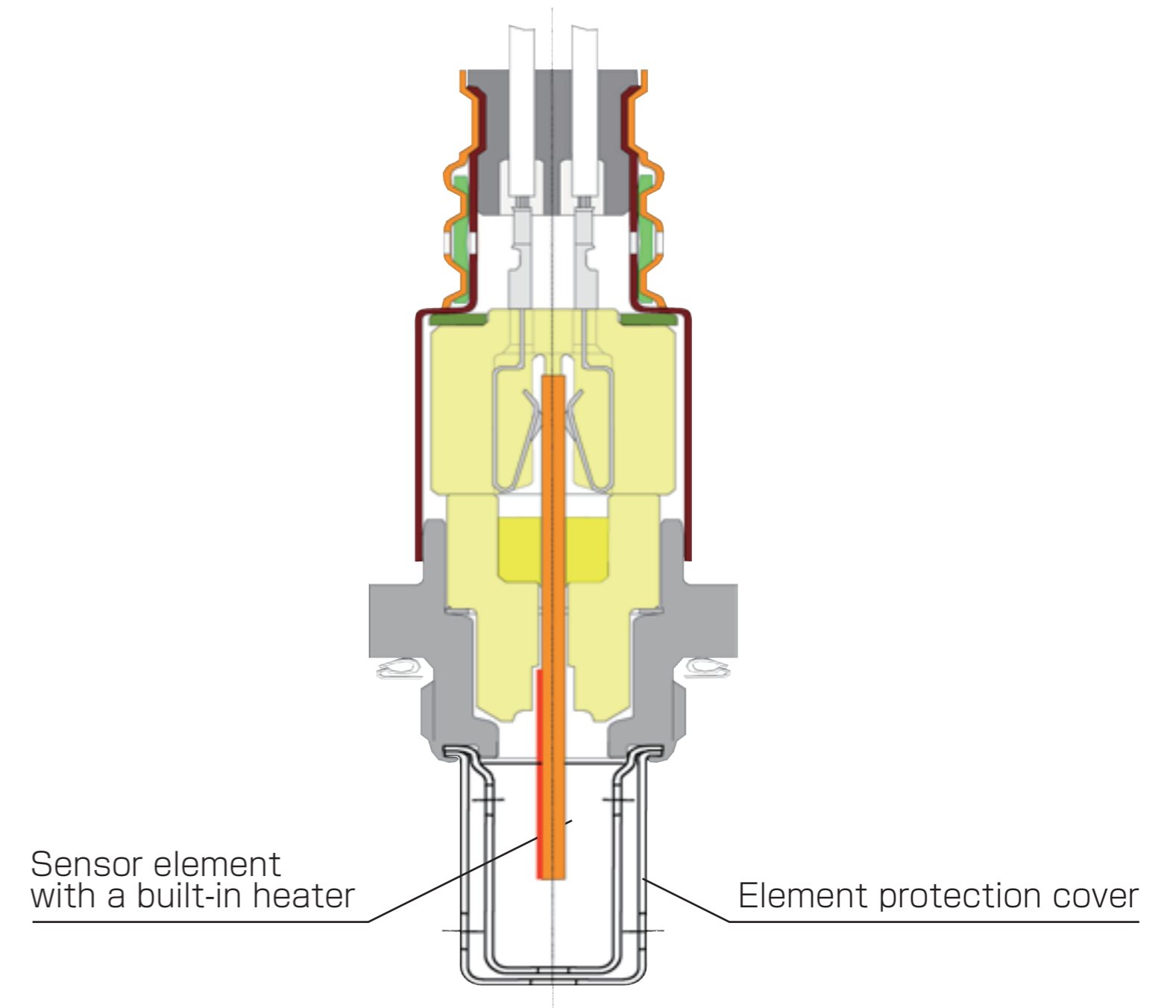

Cam Position Sensor And Crank Position Sensor

Highly precise electromagnetic pickup position sensor.

- Greater reliability using an O-ring arrangement and collar swaging
- Many variations designed to meet different engine specifications
 - Sensors with a different number of windings available for different rotor sizes
 - Direct connection type and lead wire type available for different installation conditions

■ Structure

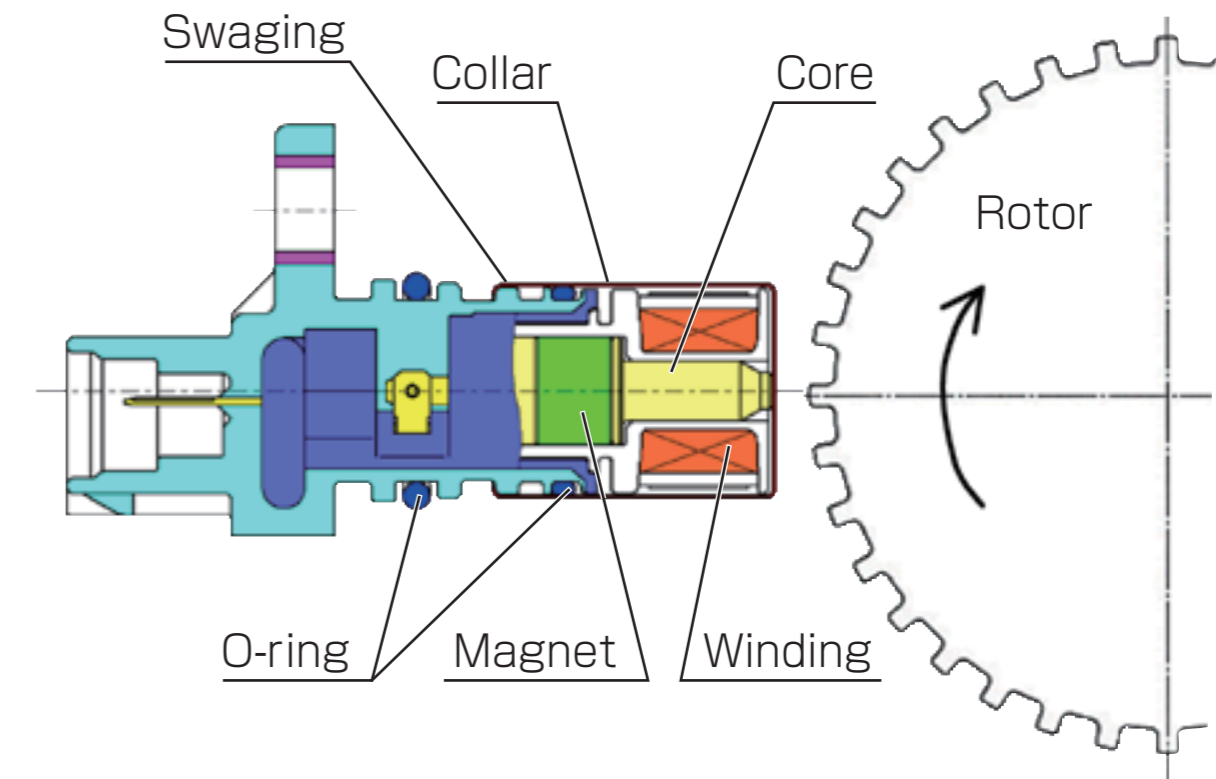

Direct connection type



Lead wire type

Ceramic Glow Plug

High heat-generation but power-saving glow plug that meets the needs for quicker start and lower emission diesel engines.

- All-ceramic heating element for higher heating efficiency
- High heat-resistant ceramic material for higher heat generation and more rapid pre-heating
- Self-control function for a simplified system

■ Structure

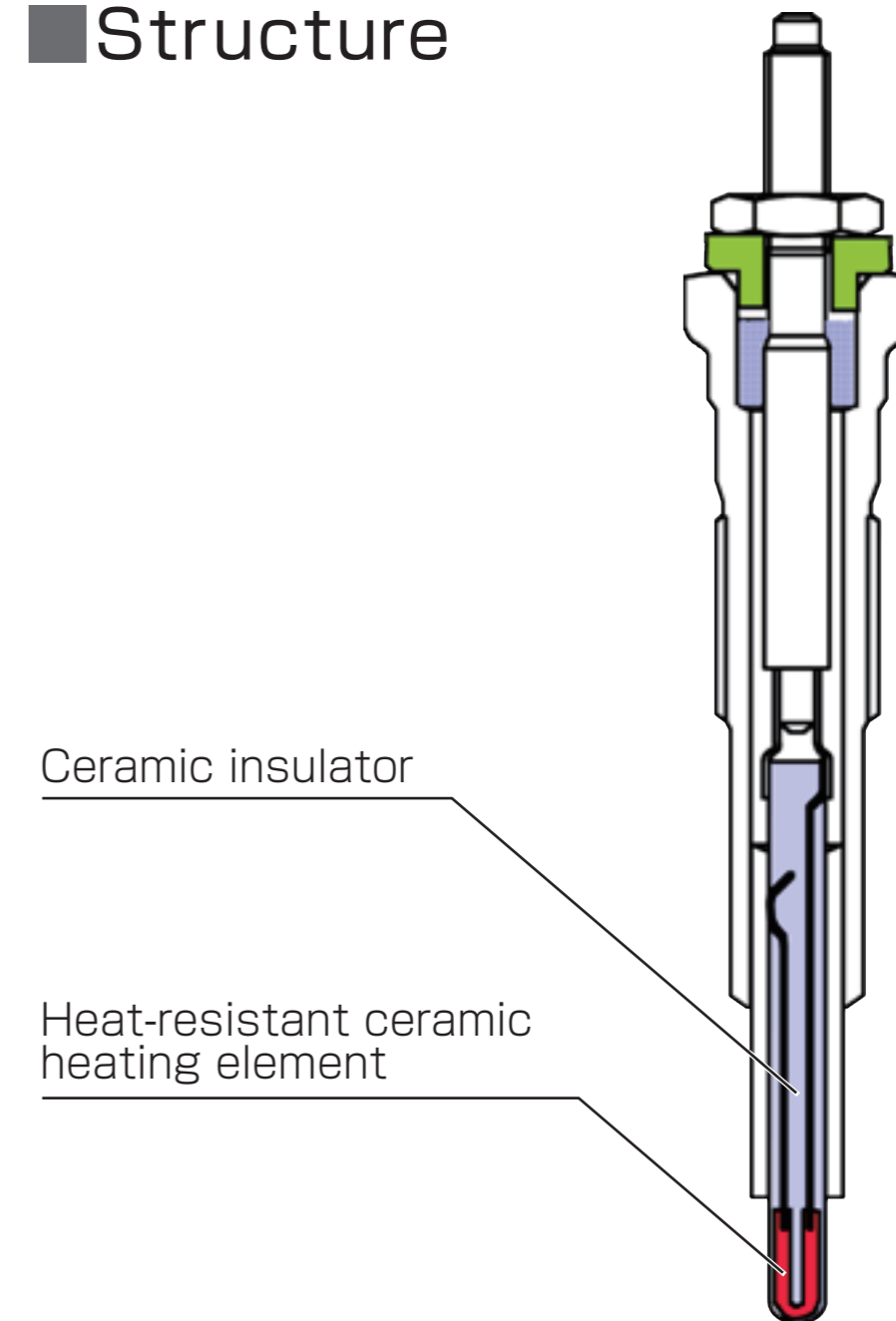

Common Rail

Ultra-high pressure fuel storage.

- More highly pressure-resistant rail made from a newly developed high strength material
- Lighter weight and a more optimum shape provided by CAE analyses
- Reduced pressure pulsation because of a built-in orifice
- More highly responsive pressure control by using a solenoid pressure relieve valve

■ Key technologies

Solenoid pressure relieve valve

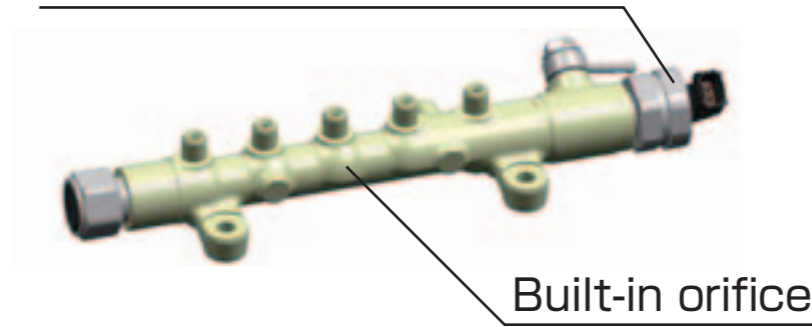

Longitudinal section of the rail

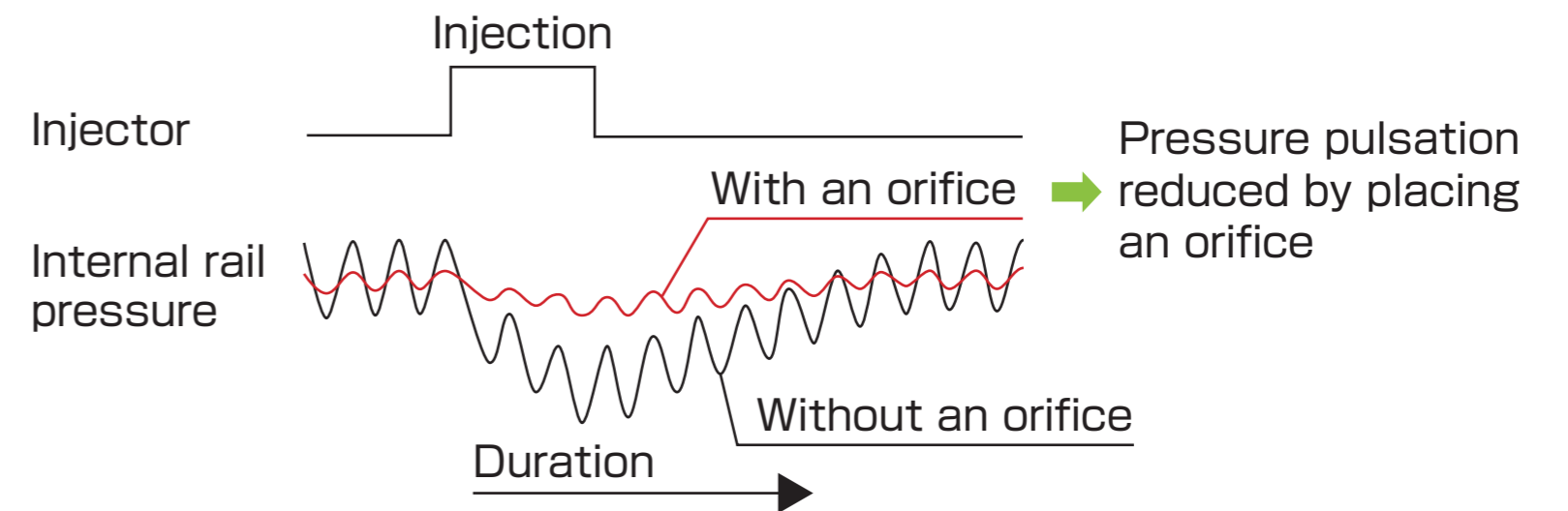
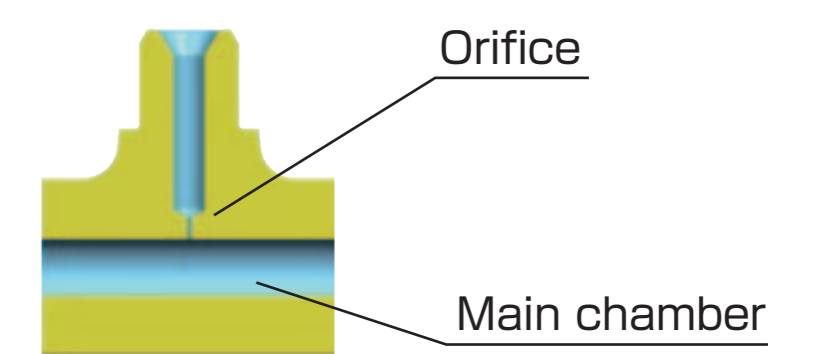

Coolant Temperature Sensor

Sensor that measures engine coolant temperature

- Output variation reduction by using a high accuracy thermistor
- High response by smaller elements and case
- High reliability for use in harsh operating environments conditions

■ Response comparison

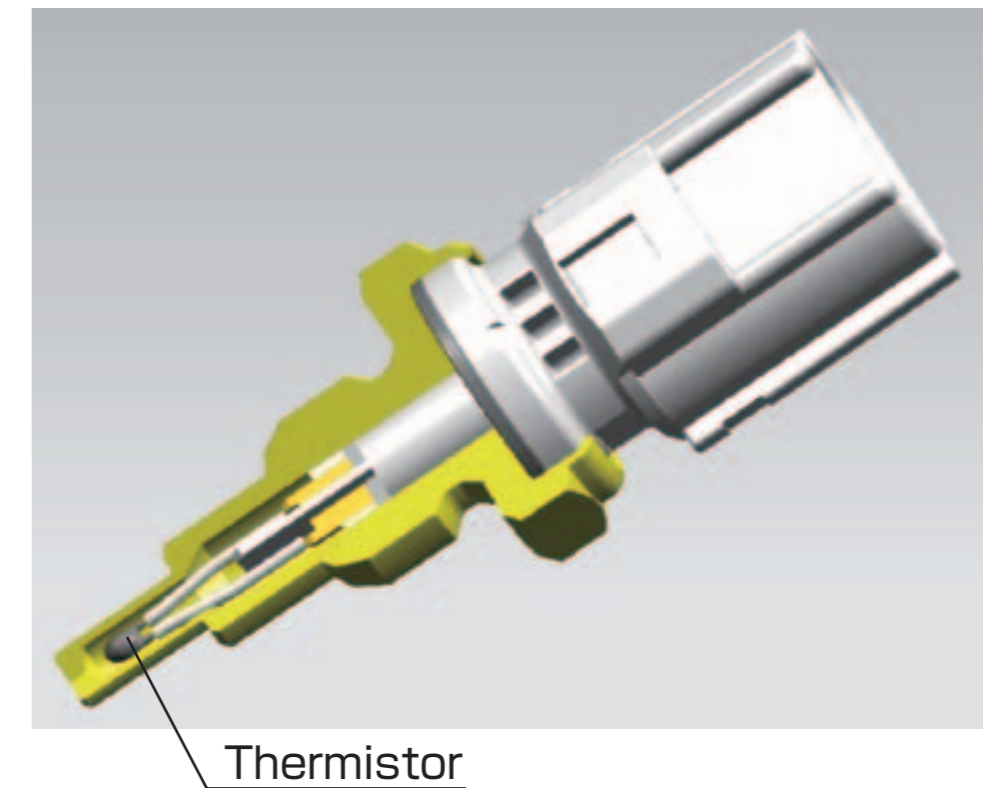
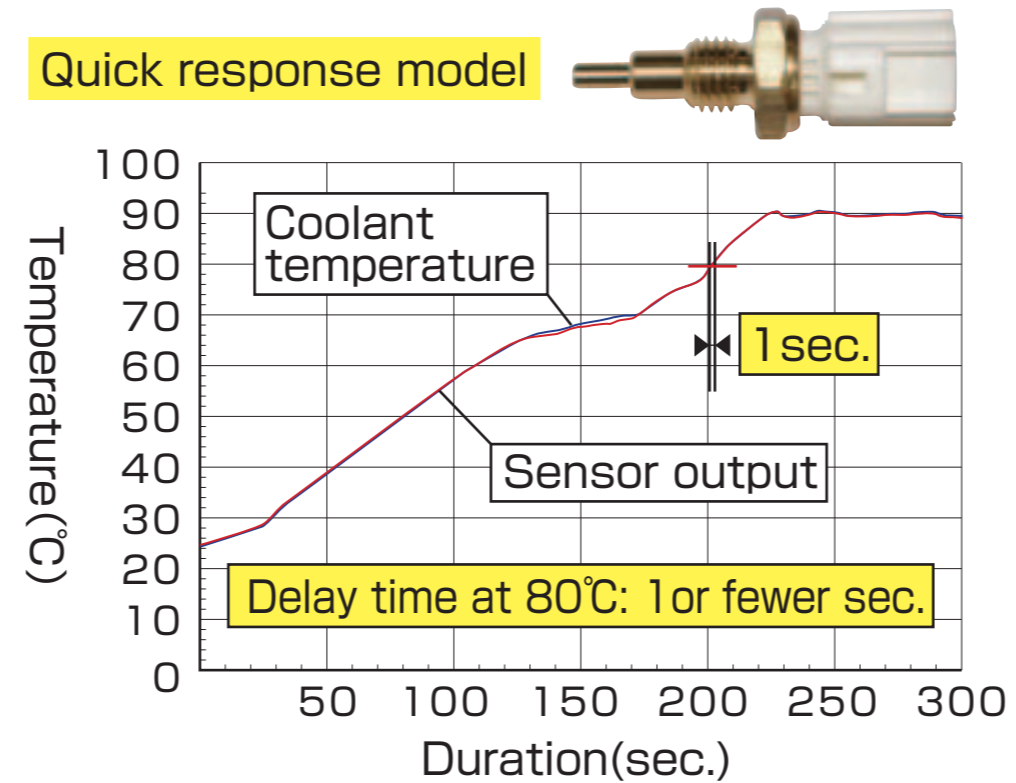
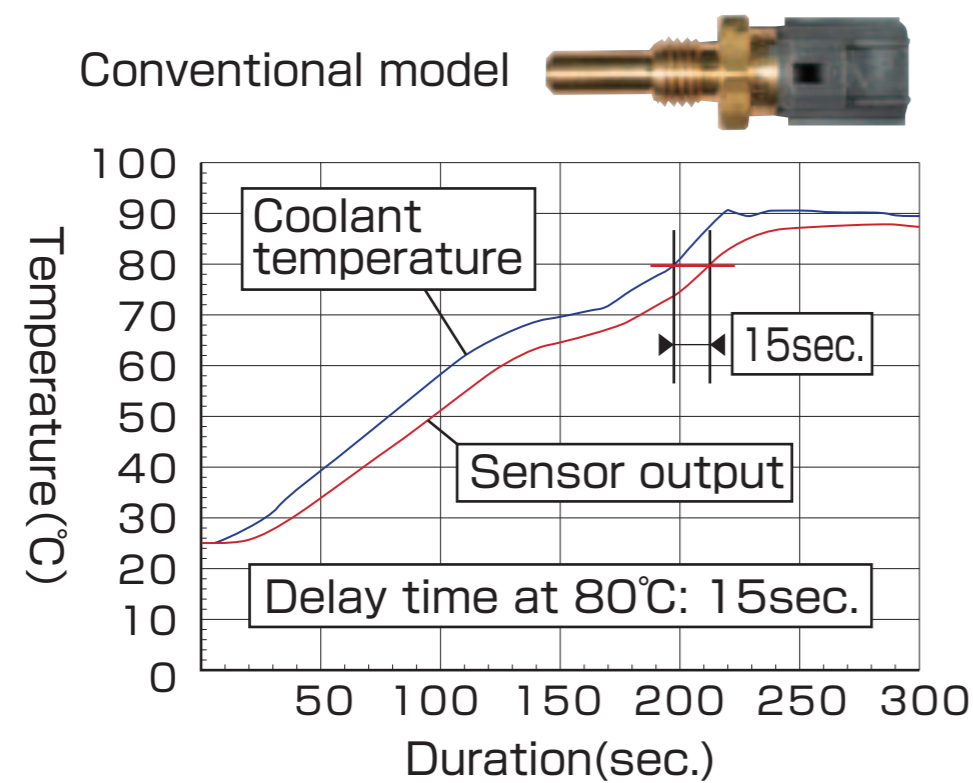

Electronic Throttle Body

Basically, electronic throttle bodies for diesel engines and for gasoline engines have the same structure. However, contrary to electronic throttle bodies for gasoline engines, those for diesel engines have not a function to control engine power because the power of diesel engines is controlled in accordance with the amount of fuel injected.

The valve of an electronic throttle body is normally open, but it is partially closed in the following conditions:

- Recirculating a large amount of exhaust gas in the event of a low engine load
- Stopping the engine without large shocks when the ignition is switched off
- Restricting the amount of intake air to increase the exhaust temperature in the event of a DPF regeneration cycle

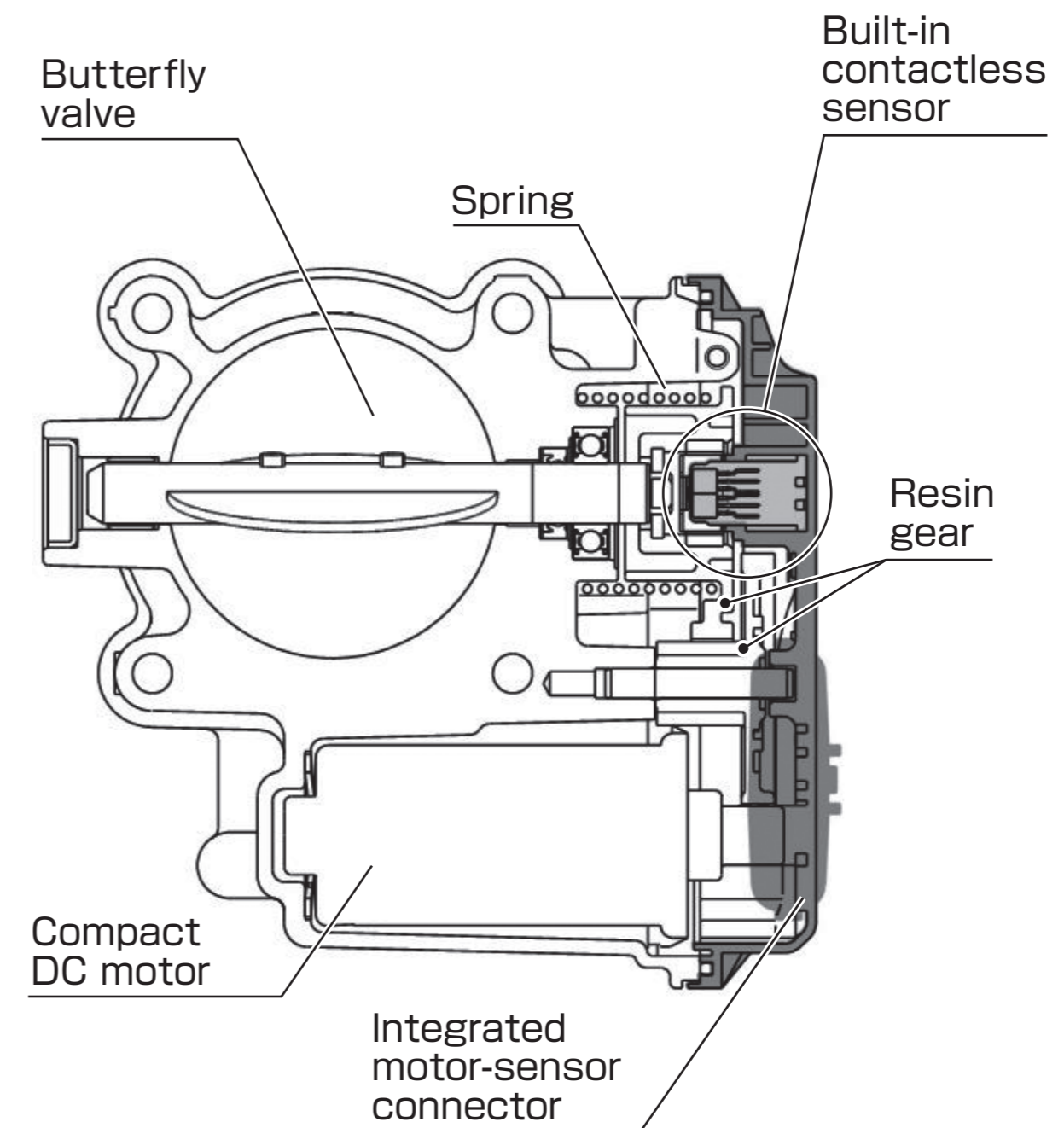

Electronic Throttle Body

- Use of a DC motor for high response and continuous air flow control
- Use of resin gears and a small motor for lighter weight and a lower cost
- Use of a contactless sensor for a longer life and high reliability

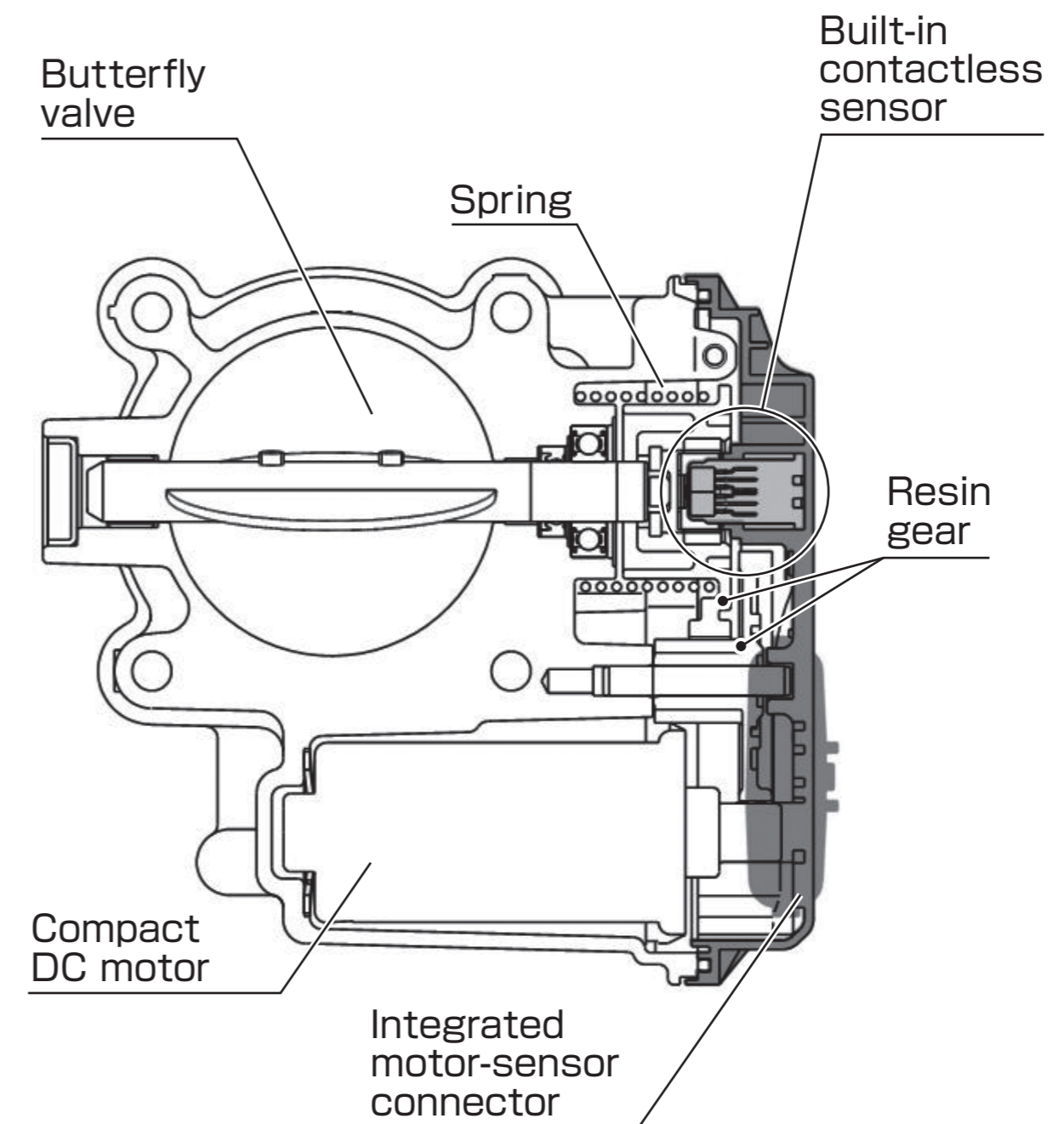

Engine Electronic Control Unit

The engine electronic control unit (ECU) is designed to have total control of the actuators and run the engine under optimal conditions based on various sensor signals transmitted under the ever-changing driving conditions of a vehicle.

- On-board custom ICs have been developed to achieve high integration and reduced size
- High-performance 32-bit microprocessors have been developed to achieve high-speed processing
- With a waterproof structure, the engine ECU can be mounted in the engine compartment
- Improvements have been made in the heat conductive performance in the Power ICs due to a reverse heat sink package directly attached to the metal case
- Build-in voltage boost circuit to drive Injectors

Exhaust Gas Pressure Sensor

The pressure sensor measures the extent to which the diesel particulate filter (DPF) is clogged with accumulated particle matter from exhaust gases. The sensor actually measures the difference between the pressure of exhaust gases entering and leaving the DPF.

- DENSO's new fluorocarbon gel with excellent corrosion resistance in the exhaust gas environment
- Two-layer gel filling structure: IC sensor chips detect pressure transmitted through the soft gel without any loss and are protected by the hard gel from damage by PM in the exhaust gas.
- Electrical trimming provided after sensor assembly for greater precision sensing

Structure

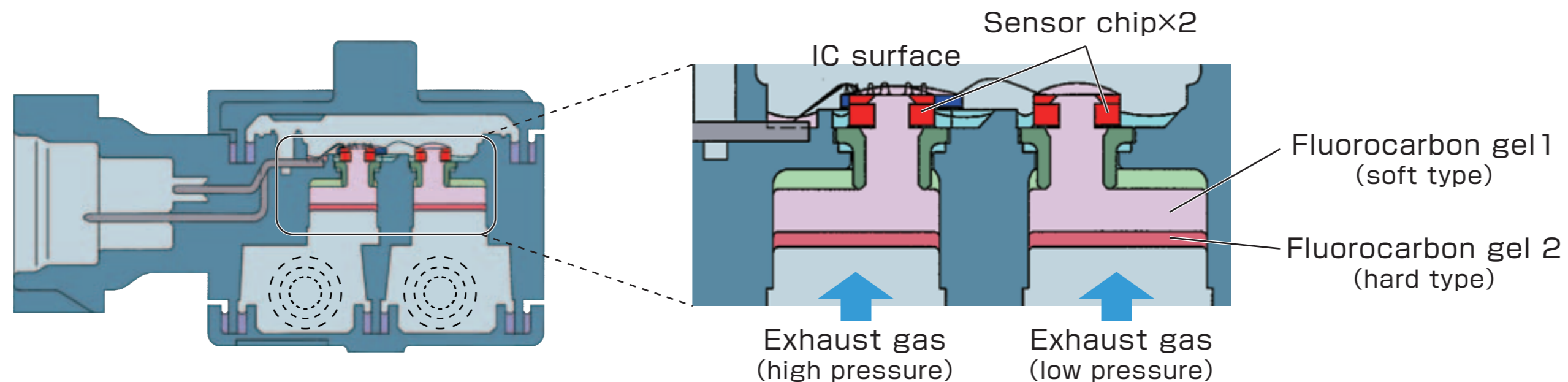

Exhaust Gas Recirculation Cooler

The small Exhaust Gas Recirculation (EGR) Cooler for a large amount of EGR with high performance and high heat-proof

- High performance with technology to decrease pressure loss
Minute offset fins are adopted.
- Heat-proof warp structure
The structure to decrease temperatures fluctuate at limited part
- The structure to prevent boil
The dimples for heat conduction control and the rib to prevent stagnation are adopted.

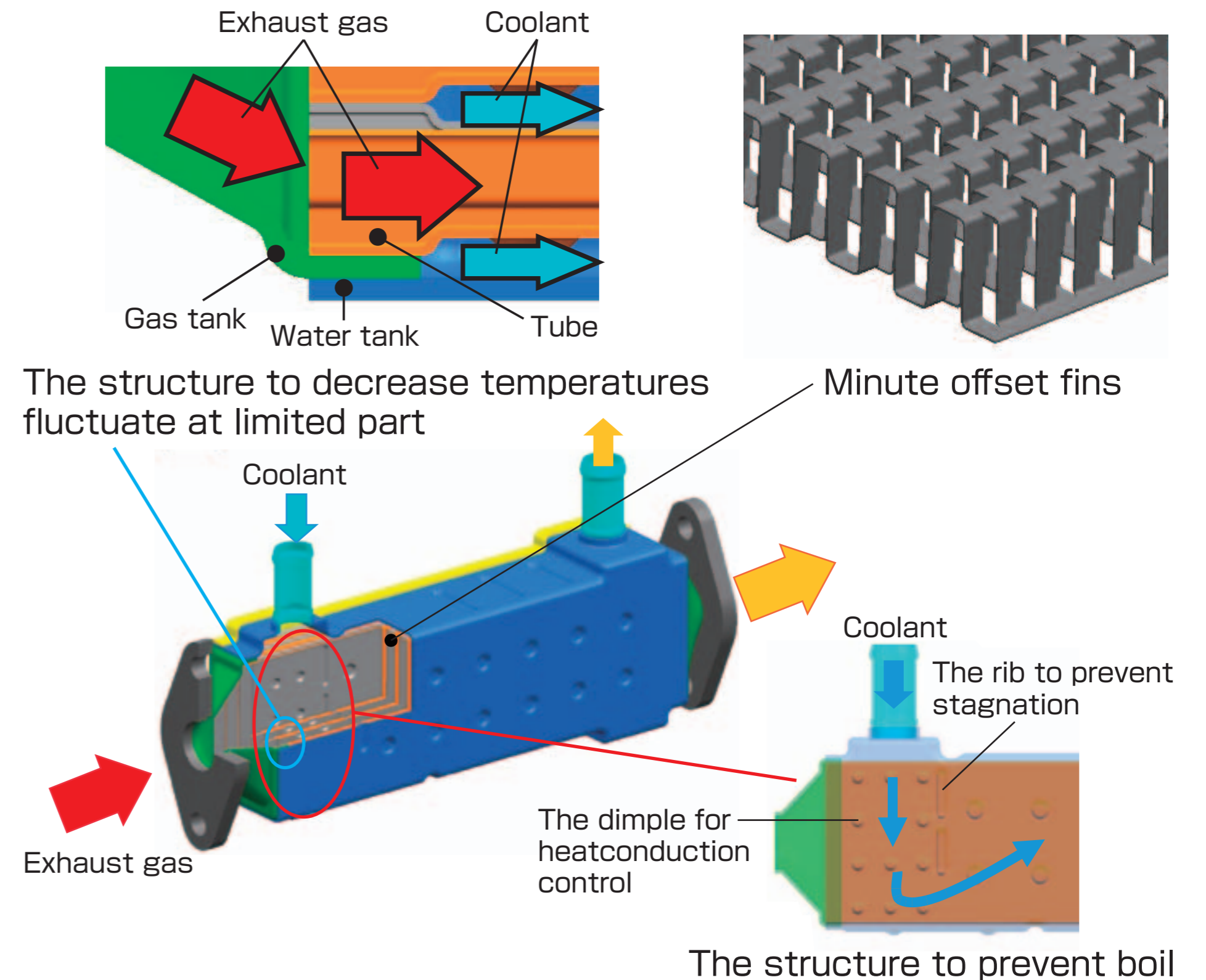

Exhaust Gas Recirculation Valve

Valve highly resistant to valve sticking caused by adhesive deposits and highly effective for NOx emission reduction.

- Valve with an overturn mechanism for deposit cleaning action to prevent valve sticking and a high torque DC motor for higher resistance to valve sticking caused by adhesive deposits
- Low pressure-loss butterfly valve for a smaller product size and a larger amount of exhaust circulation
- Butterfly valve with a pressure-balancing mechanism for the more accurate control of exhaust circulation at high pressure
- Contactless hall IC valve position sensor for higher sensor signal communications reliability

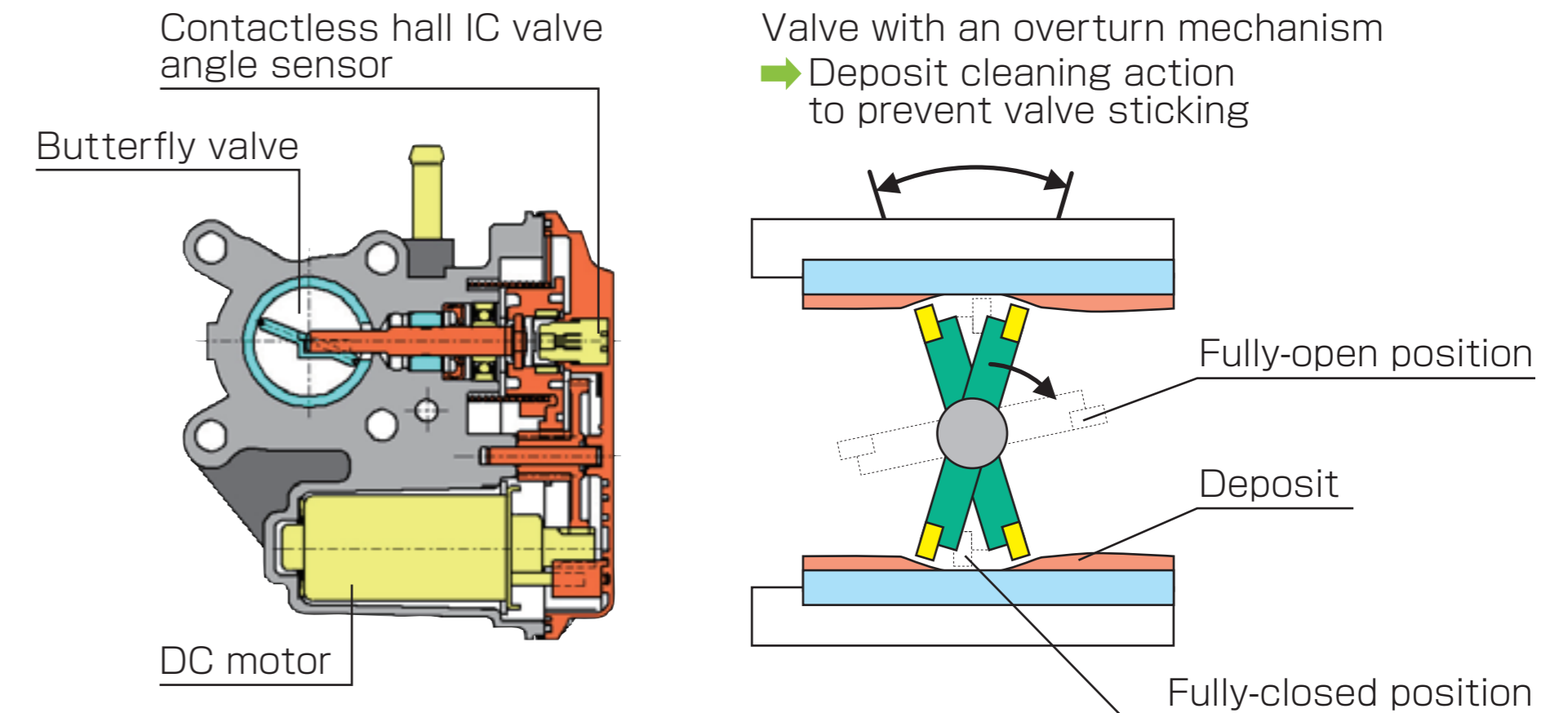

Appearance

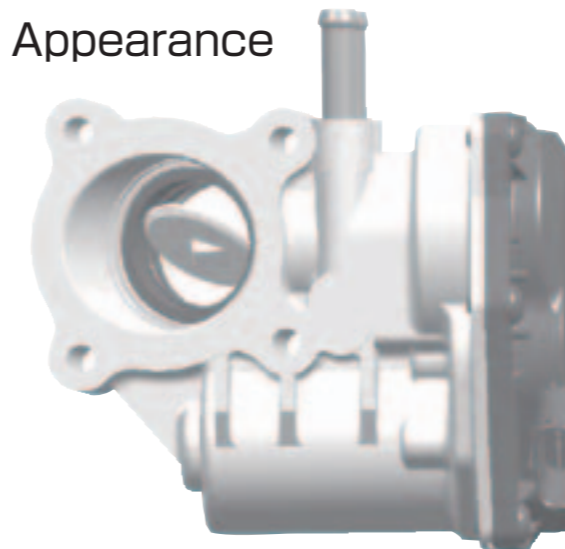

Exhaust Gas Temperature Sensor

Thermistor temperature sensor capable of precisely detecting vehicle exhaust temperature.

- Simplified sensor shape for easier installation
- Greater reliability for use in harsh vehicle operating environments
- Highly precise temperature detection due to fine grinding and a homogeneous mixing of thermistor materials and greater precision molding
- Wide range of temperature measurements by using the perfect blending of thermistor materials
- Faster response by using a smaller temperature detector and a thermistor element



Exhaust Port Fuel Injector

High performance and high reliable injector to meet stricter diesel engine emission regulations.

- Slit nozzle for finer fuel atomization
- Low fuel pressure system for a simplified injection system
- Voltage drive system for a low-cost injection system
- Simplified injection system for higher reliability

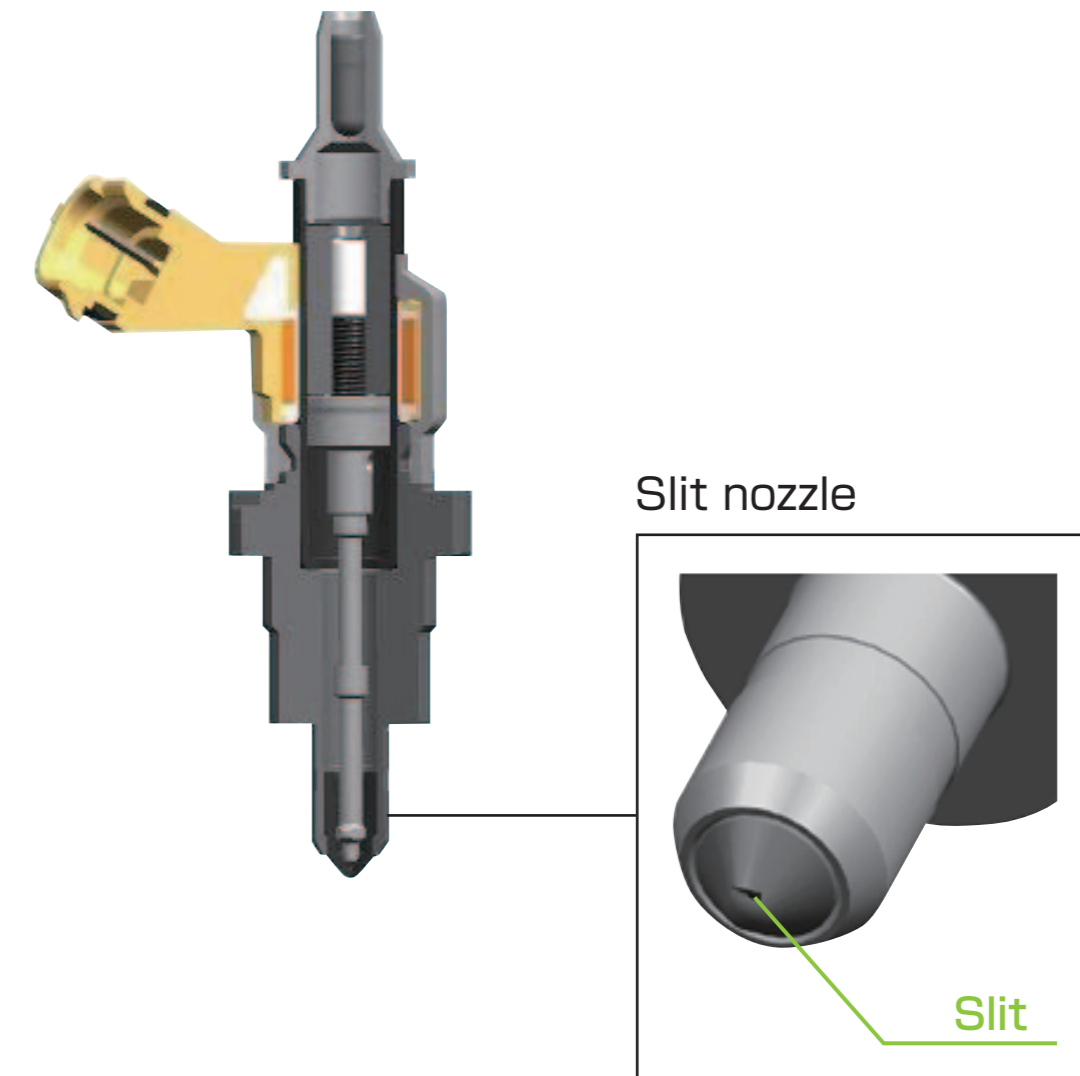

Fuel Filter

Compact and long life high-performance fuel filter that provides high filtration efficiency.

- High foreign particle filtration efficiency to protect the common rail
- Compact size and a longer life thanks to a honeycomb structure
- Filter paper with two layer structure contributes to high filtration efficiency and long products life
- Less waste produced by replacing only the fuel filter element
- Less frequency of fuel filter replacement with the help of a fuel filter element condition sensor (Periodic replacement → replacement when the fuel filter element is clogged)

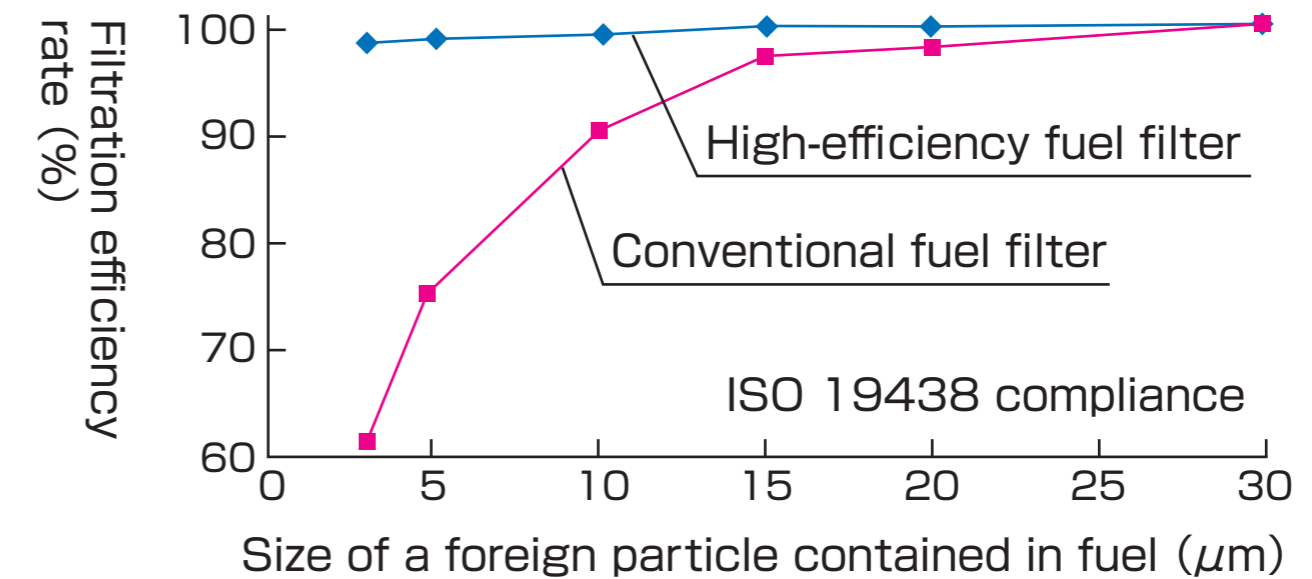
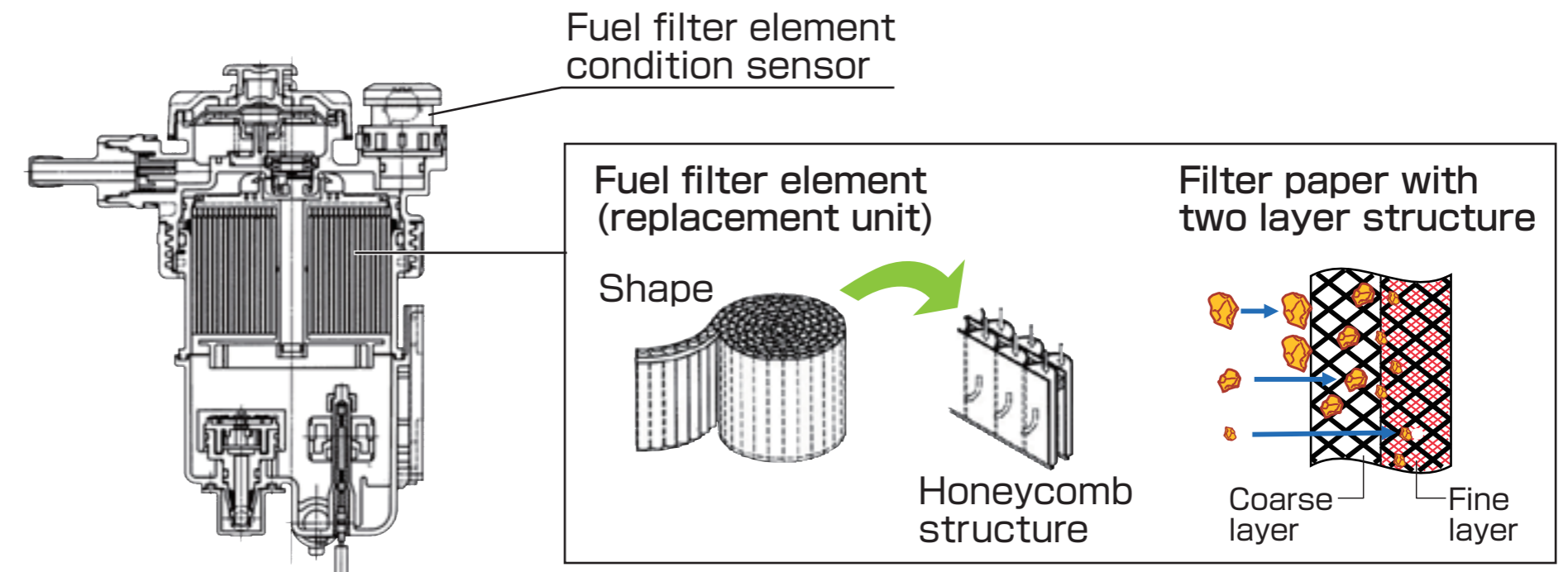

Intercooler

Heat exchanger to cool incoming air for higher engine power and fuel efficiency.

Higher cooling performance achieved by:

- Inner fin design: Changes in the shape of the inner fin for higher heat transfer
- Cooling fine design: The shape of the louver fin effective for heat transfer designed based on DENSO's know-how accumulated in the development of radiators

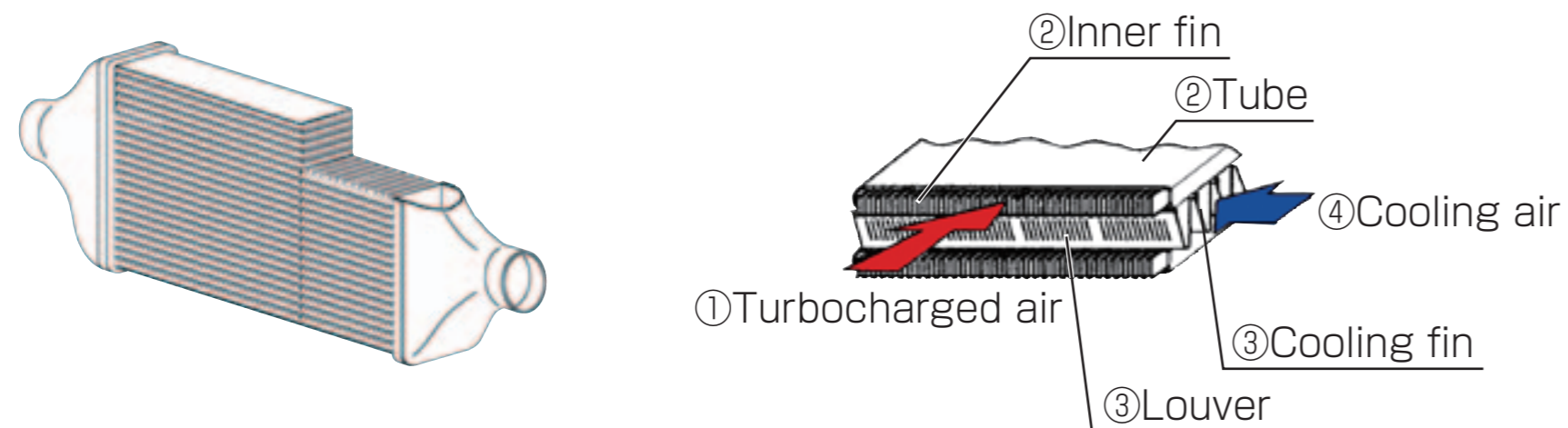

Key technology

Continuous improvement of the inner fin for enhanced cooling performance.

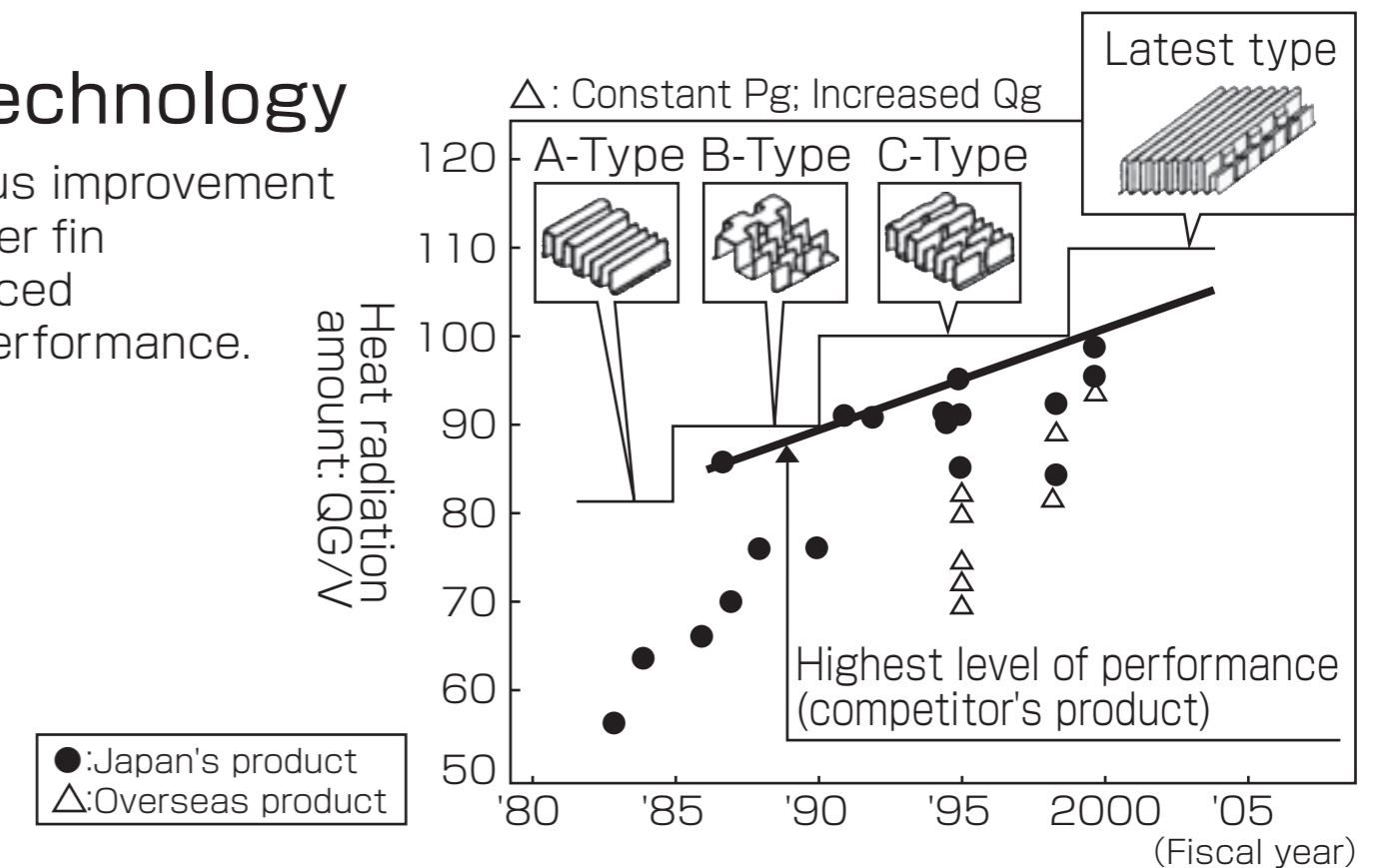

Heat transfer route

- ① High-temperature turbocharged air
 Transmission of the heat of supercharged air to the tube when the air passes through the tube.
- ② Tube and inner fin
 Transmission of the heat from the tube to the cooling fin.
- ③ Cooling fin
 Transmission of the heat from the tube to the cooling air. (incoming outside air)
- ④ Cooling air

Solenoid Injector for i-ART[®] system

- DENSO's solenoid injector works with diverse environments and fuel types and ensures highly efficient fuel injection.
- Our solenoid injector achieves clean emissions and high engine performance through accurate and ultra-high pressure multiple fuel injection.

Maximum injection pressure: 250 Mpa

Number of injections during one combustion cycle: 9
(minimum injection interval: 2/10,000 second)

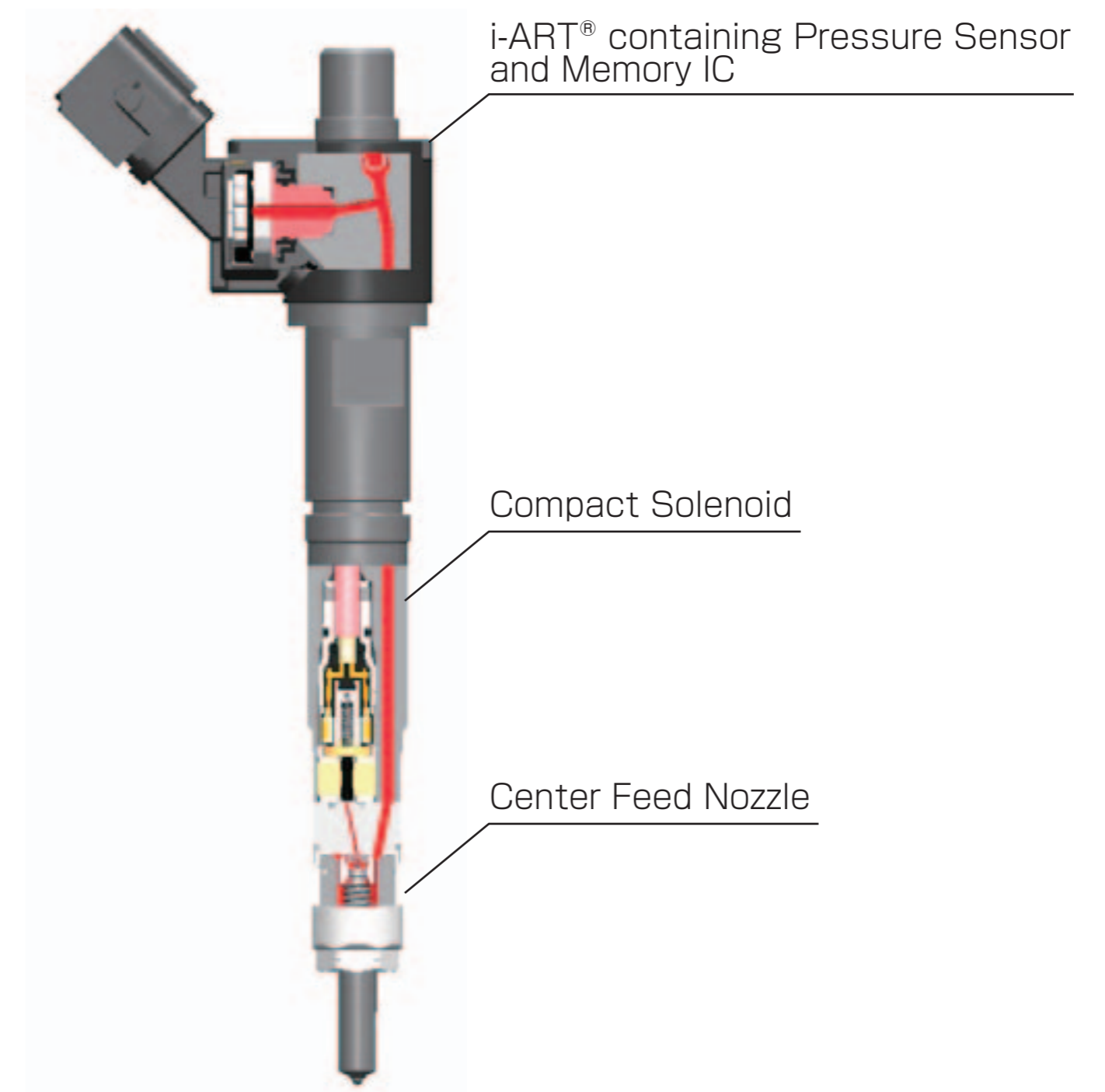

Solenoid Injector for i-ART[®] system

- The i-ART[®] system is designed to control the amount of injected fuel with a high level of accuracy with the aid of the pressure sensor in the injector.
- The i-ART[®] system realizes injection feedback control with a high level of accuracy through the direct detection of pressure during injection and high-speed calculation by onboard computers.

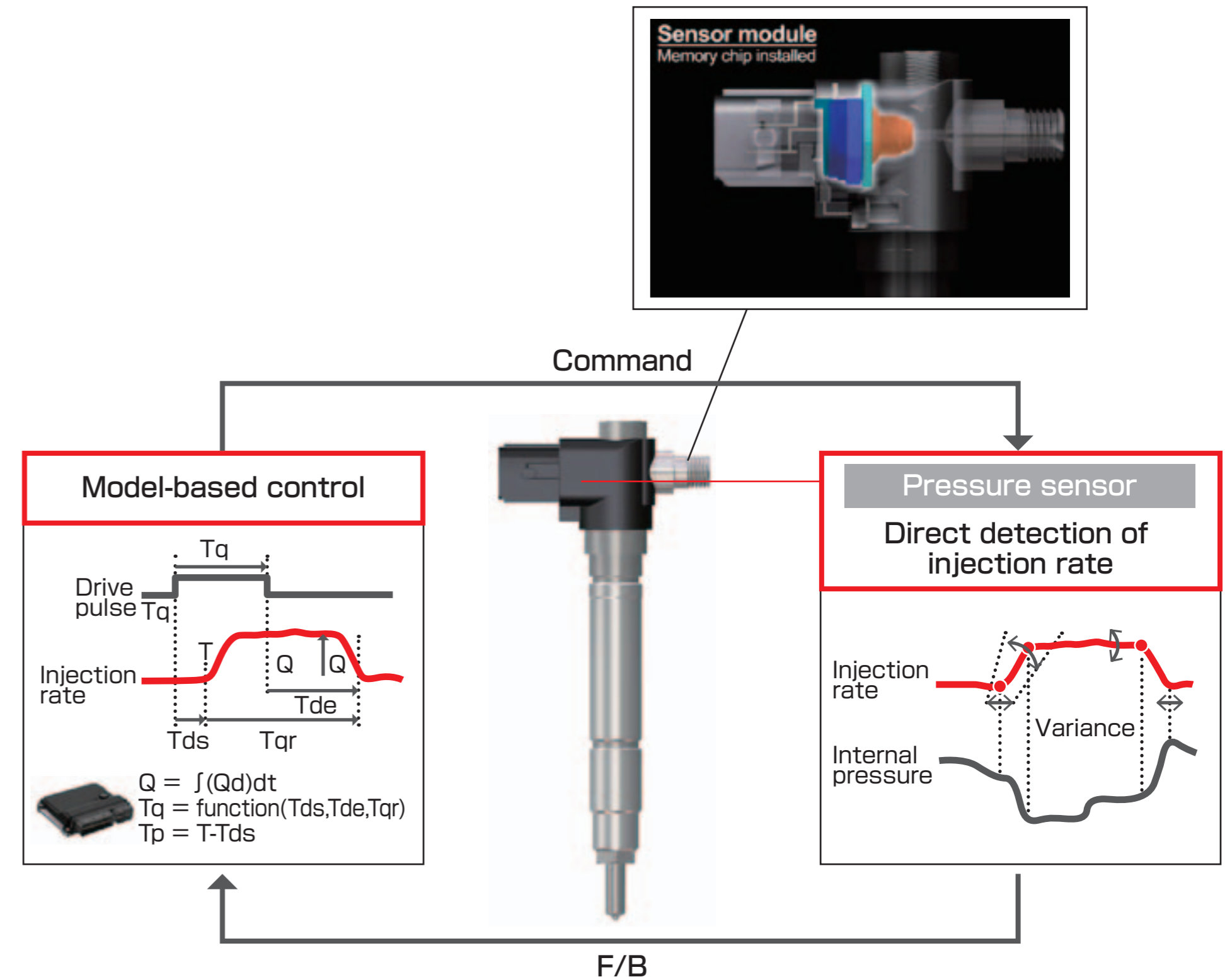

Turbo Pressure Sensor

Pressure sensor to measure the pressure of turbocharged intake air.

- Compact and highly mass-producible piezo resistance turbo pressure sensor
Pressure detection with the piezo resistance effect of silicon: resistance value changes due to the distortion upon the application of a voltage
- Ultimately simplified structure using a bare chip mounting method
Sensor and circuit chips are directly mounted on the resin case (PPS-G40) to reduce the number of components to its smallest possible limit
- DENSO's proprietary on-chip noise prevention technology
On-chip noise cancellation circuit requires no noise prevention components

■ Structure

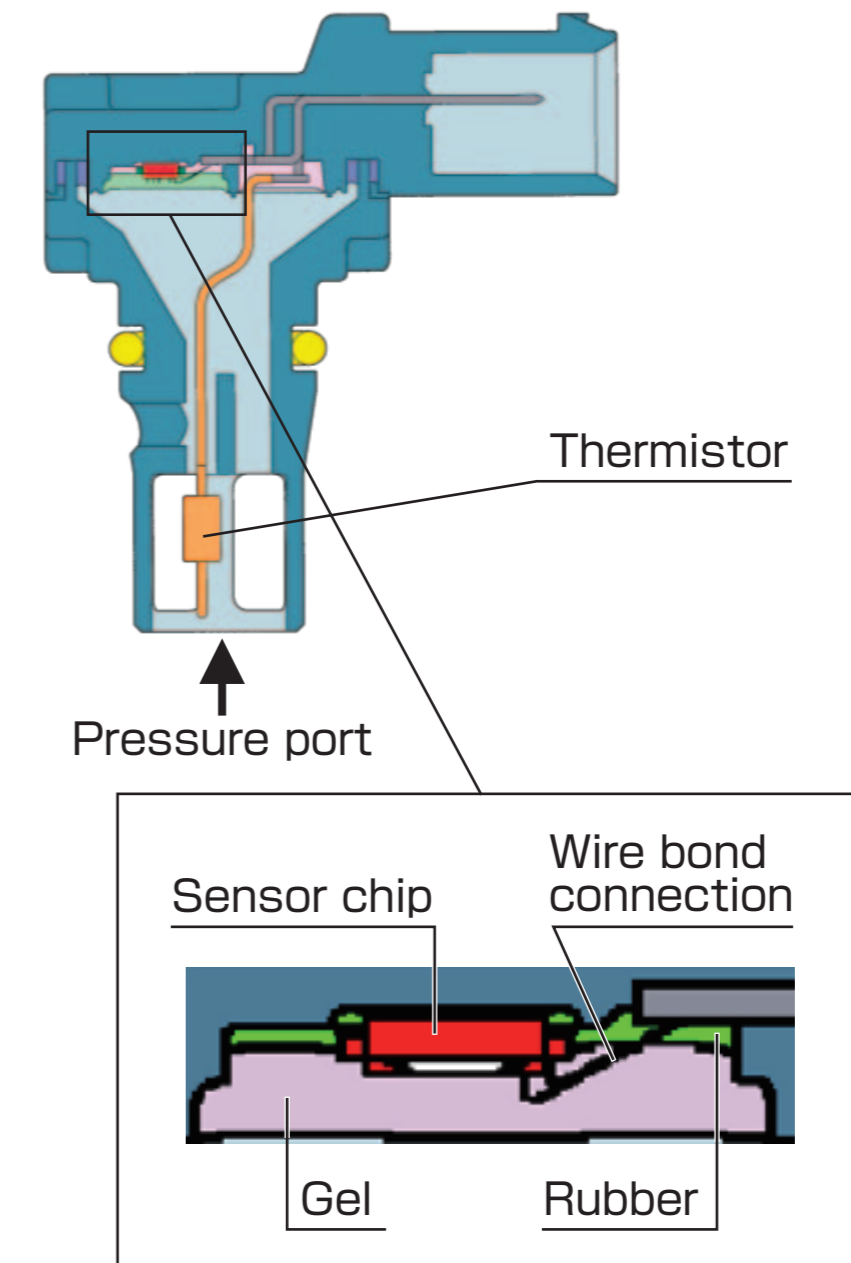

Turbo Pressure Sensor

- DENSO's own impact absorbing surface structure can cope with an increasingly harsh environment in the intake manifold.
A two-layer surface structure made of full gel and rubber allows the sensor to be used in harsh environments in the intake manifold
- Electrical connections without soldering.
(wire bond connection)
A wire bond electrical connection between devices and terminals provides higher reliability and requires no soldering. (no use of lead)
- The intake air pressure and temperature can be measured in real time.
It is possible to detect them with high reliability even in a severe supercharging environment to return Exhaust Gas Recirculation (EGR).

■ Structure

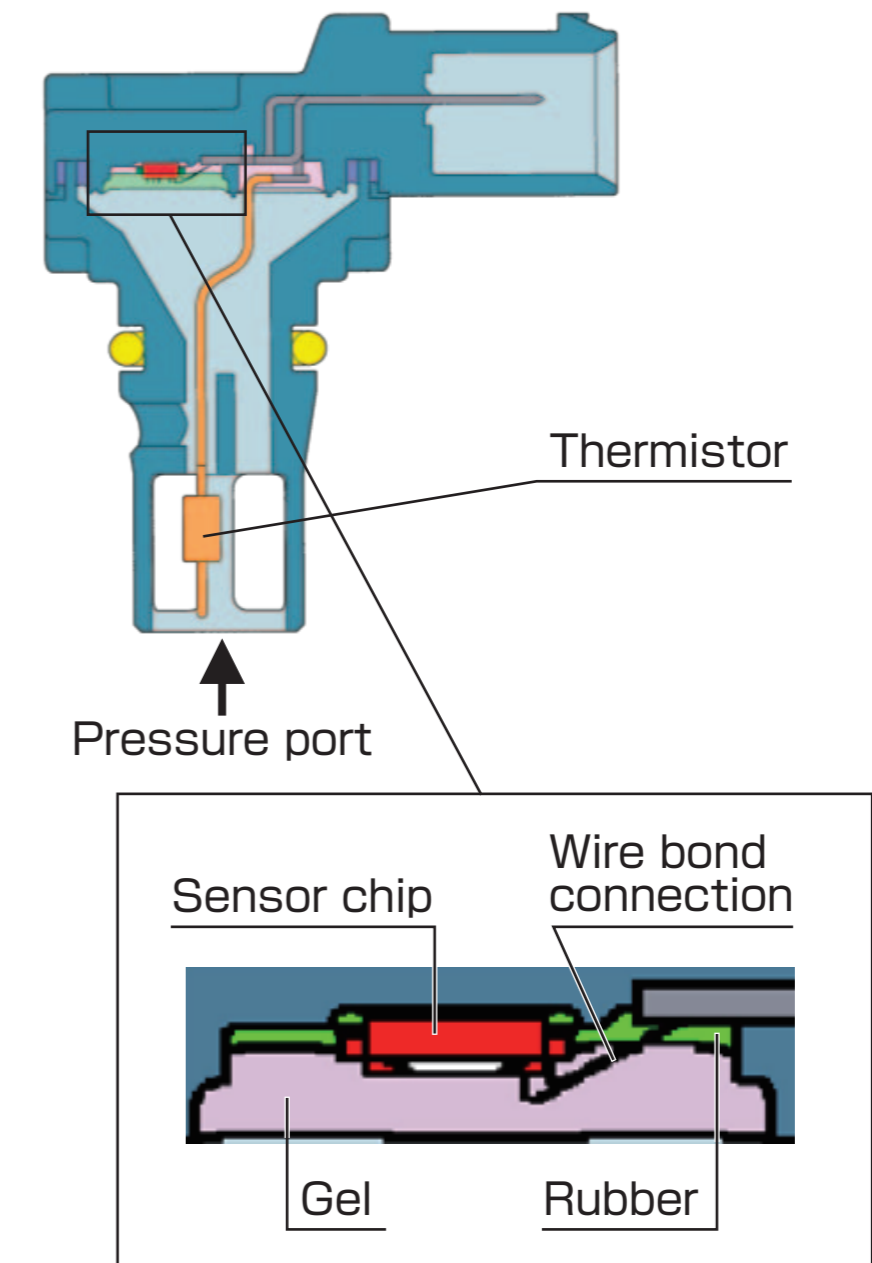

Ultra-high-pressure pump

The nucleus of common rails that produces ultra-high pressure

- This fuel pump contributes to clean, less-energy-consuming diesel engines through ultra-high-pressure performance and drive torque reduction.
- DENSO's unique control valve mechanism provides this fuel pump with one of the highest performance levels in the world and high robustness against a variety of fuel types.
- The combination of a single cylinder and a multi-action cam helps achieve the compact fuel pump.

■ HP5S

