



# ECT2000

*Diagnose Electrical  
Circuits Like a Pro!*

**Manual**

**POWER PROBE®**

*English - Español - Français - Deutsch - Italiano*

# Contents

Congratulations .....	4
Parts.....	5
<b>The SMART transmitter .....</b>	<b>6</b>
Characteristics of the Short/Grounded Circuit signal .....	8
Characteristics of the Open Circuit signal .....	9&10
<b>The SMART receiver .....</b>	<b>11</b>
Battery Installation.....	12
Testing the Smart Receiver .....	12
Pulse Mode.....	12
Locking the Sensitivity of Short//Grounded Circuit signal .....	14
Locking the Sensitivity of Open Circuits.....	14
Direction to Short.....	15
<b>How to Use the ECT-2000 in Diagnosing Circuits .....</b>	<b>16</b>

# Contents

How to Trace Out a Short Circuit to Chassis Ground.....	17
Isolate your Circuit .....	18
Verify the Short Circuit to Ground.....	18
Short Circuit inside a Wire Harness.....	19
Reception Distance and What that Means .....	20
Tracing Circuits that are Shielded.....	21
Open Circuit Signal vs /Grounded Circuit Signal .....	22
How to Trace an Open Circuit .....	23
Verify an Open Circuit.....	23
Bench Tracing a Wire Harness.....	24
Tracing out Battery Drain or Current Draw.....	25
Circuit Wiggle & Flex Test .....	26
Index .....	27

# Congratulations

Thank you for choosing the Power Probe “SMART ECT-2000” (Electronic Circuit Tracer- 2000)

This instruction booklet will give you some valuable diagnosing tips gathered from the field and from our testing lab. This instruction booklet has convenient references that will take you to appropriate pages that provide more information and clarification. Taking the time to read this instruction booklet carefully will give you valuable insight to these detailed techniques in tracing automotive circuits.

We designed the ECT-2000 as a quick solution to your automotive circuit problems. The ECT 2000 consists of 2 main components. A SMART transmitter and a SMART receiver along with a set of connection adapters that will help you:

- Locate short circuits without unnecessarily removing plastic panels, molding, and carpet.
- Trace wires to see where they lead
- Locate electrical components in the vehicle
- Find open circuits, switches or breaks in wires
- Trace and locate the cause of a severe battery drain
- Test and find intermittent connections
- Check continuity with the assistance of the Power Probe III

These features are extremely handy for the professional technician that understands automotive electrical. An appropriate schematic or wiring diagram is always useful and many times necessary when tracing circuits. The better you understand your circuit, the better the ECT-2000 can assist you.

# Parts

English



#PNECT000R  
SMART receiver

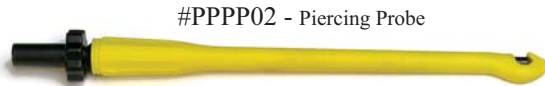

#PPPP02 - Piercing Probe



#20014 - Universal Wire Adapter\*



#AA6  
Back  
Probe



#AA4  
Blade  
Probe



#AA3



#AA1



#AA2

Light Bulb Adapters



#PNECT057  
Alligator Clip Adapter

#PN012SET  
Battery Hook-up  
Clip Set



#PNECT000T  
SMART transmitter

## Included in the Kit:

- SMART transmitter
- SMART receiver
- 1-Blade Probe\*\*
- 1-Back Probe\*\*
- 3-Light Bulb Adapters\*\*
- 1-Piercing Probe
- 1-Alligator Clip Adapter
- 1- Battery Hook-up Clip Set
- 1-Universal Wire Adapter\*:

*(You can solder to any connection for custom use.)*

\*Extra universal wire adapters can be purchased. (Sold in packs of 5, Part #PNECT050)

All banana jacks/plugs are standard 4mm making other test leads or Adapters usable with this product.

\*\*See pg. 16 for application

# The SMART transmitter

The SMART transmitter is designed to generate Grounded Circuit signals and Open Circuit signals. The grounded and the open circuit signals are very different from each other, so it is very important to understand the differences in each signal type. (see “Characteristics of the Short/Grounded Circuit Signal” pg.. 8 and Characteristics of the Open Circuit Signal” pg..9)

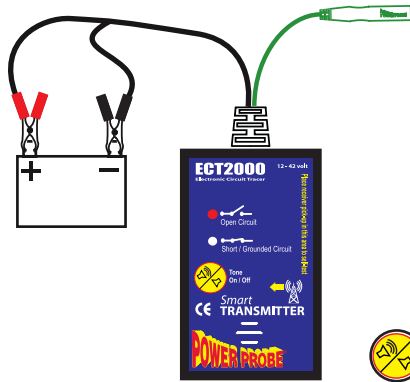

## Power Lead

The 20 ft. power lead of the SMART transmitter supplies power by connecting directly to the vehicles battery and the long length provides easy access to circuits throughout the vehicle. The RED clip connects to the positive side of the battery and the BLACK clip connects to the negative. It can be connected to a power source from 12 to 42 volts.

## Signal Lead

The signal lead with green banana jack, plugs into the assortment of adapters, probes, and clips that are provided for you in the ECT-2000 kit. These accessories simplify connecting to your circuit.



## Tone On/Off - Toggle Tone

“Tone On/Off” button toggles the tone of the SMART transmitter’s speaker on or off.

The toggle tone feature of the SMART transmitter gives you the ability to detect changes in the circuit to detect intermittent problems. (See “Circuit Wiggle and Flex Test” pg.. 26)

## Self-Test

The area located on the face of the SMART transmitter, with the words “Place receiver pick-up in this area to self-test” is used for testing the SMART receiver.

After connecting the SMART transmitter's 20 ft. power lead to the vehicle's battery, a signal is generated through the green signal wire and banana plug. This is connected to the circuit you want to trace. The signal will radiate along the circuit, which you can detect by using the SMART receiver. There are two types of circuit signals that the SMART transmitter generates. They are the Grounded Circuit SIGNAL and the OPEN CIRCUIT SIGNAL.

It is very important to familiarize yourself with both of these signals and how they work in your circuit. The "Grounded Circuit signal" and the "open circuit signal" are different from each other, which you should understand. (See: "Characteristics of the Short/Grounded Circuit Signal" pg. 8 and "Characteristics of the Open Circuit Signal" pg. 9&10)

**The 2 main features of the ECT2000 is that it transmits a signal into a circuit with the SMART transmitter and then you trace it with the SMART receiver . The easiest way to insure that you are following the problem circuit is to isolate it from other parallel circuits.**

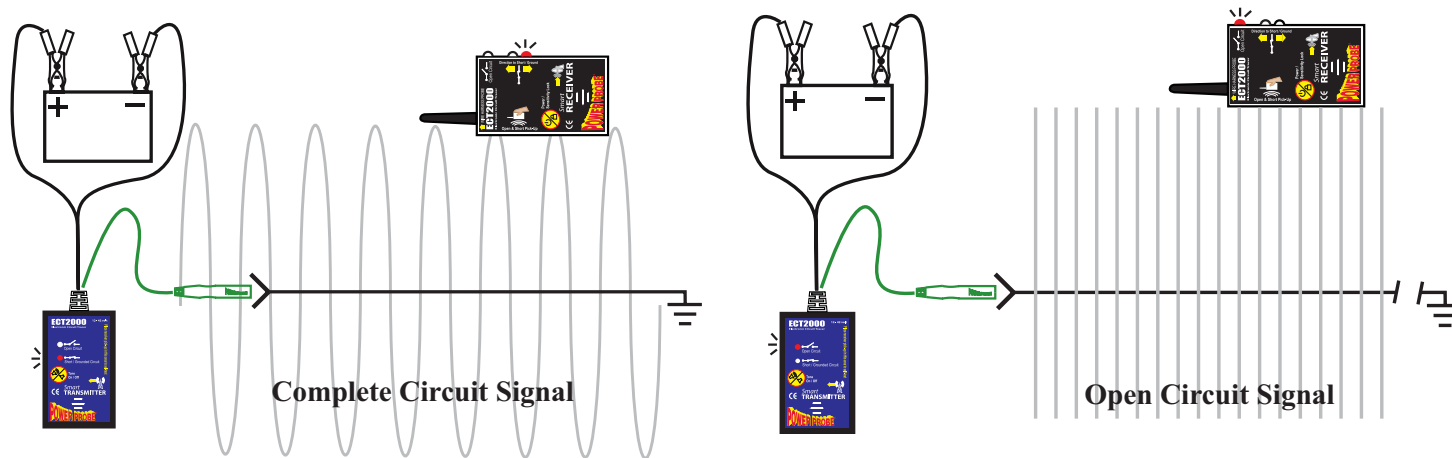

## Characteristics of the Short/Grounded Circuit Signal:

### 1. Strongest when flowing exclusively through one wire

When the signal is conducting through only one wire, the signal strength is at its maximum because 100% of the signal is traveling through that wire exclusively to return back to the negative side of the battery. If the signal branches out to parallel circuits, its strength divides and of course is weaker in each branch of the divided circuit. But when the signal recollects through the single negative cable to return to the battery, the signal strength is at its maximum again because 100% of the signal is concentrated through the single negative battery cable. (see “Isolate the Circuit You are Tracing” pg. 18)

### 2. Travels the path of least resistance

In case of a short circuit that blows its fuse reliably, you can sometimes get away with not having to isolate the circuit. The majority of the signal will follow the path of least resistance through the short and then back to the battery. In fig.1, you can see the majority of the signal travels right to the short circuit. You can also see only a small portion of the signal running through parallel wires.

### 3. A 4 KHz Polarized Signal

The fact that the Grounded Circuit signal is a 4 KHz polarized signal provides directional information for the SMART receiver to pick up. This capability to indicate the direction to the short or ground takes the guesswork out of tracing grounded circuits. (See “Direction to the Short” pg. 15)

### 4. Carries a current of only 100 mA.

When generating a short/Grounded Circuit signal, a maximum of 100 milliamp flows from the signal lead. This keeps you safe from damaging sensitive computer circuits.

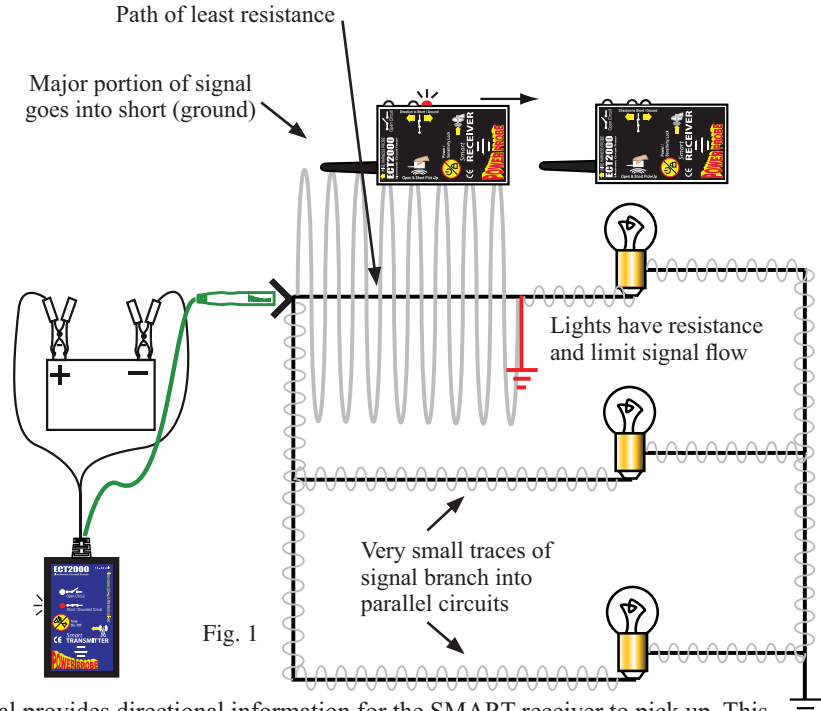

**Characteristics of the Open Circuit Signal are:**

**1. Transmits through NON Conductive Materials**

The signal that the ECT transmits when tracing open circuits, radiates what is called an E-field. For the sake of simplicity we will refer to an E-field in this manual as an “Open Circuit Signal”.

The open circuit signal radiates from wires and passes through non conductive material such as dry carpet, plastic panels or plastic molding. The SMART receiver is used to detect these signals so you can trace and locate the open or break in the circuit.

(See “Locking the Sensitivity” pg. 14)

**2. Easily Shielded by Conductive Materials**

The open circuit signal is however easily shielded by conductive materials such as metal, wet carpet, neighboring wires in a harness and even your hand. This means that if conductive materials are between the transmitting wire and the SMART receiver, the open circuit signal will not penetrate through and therefore not be detected by the receiver.

So it is necessary to be aware of possible shielding issues and try to avoid them as much as possible.

A great alternative to the SMART receiver in detecting open circuit signals is to use the Power Probe III by direct contact. (see “Verify an Open Circuit” pg. 23)

*(continued on next page)*

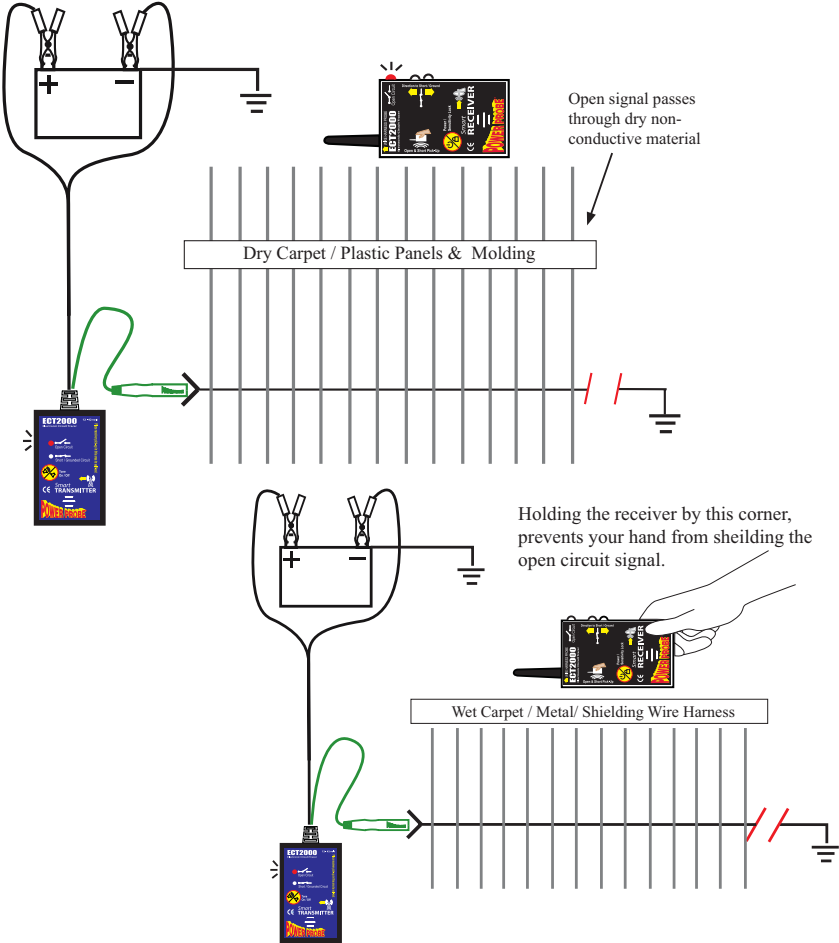

### 3. Capacitive Coupling to Parallel Floating Circuits

Another characteristic of the open circuit signal is that it will capacitive couple to parallel floating circuits. (See: “Bench Tracing a Wire Harness” pg. 24)

### 4. Travels to ALL Open Ends

In Fig. 1 we are injecting an open circuit signal into a parallel circuit that has three wires. Two of those wires lead to open switches and the other leads to the open/break. As you can see the open circuit signal travels to all open ends. This makes it necessary to isolate the problem circuit away from the others.

### 5. Can only be present in a circuit when there is a resistance greater than 100 ohms

(See: “Open Circuit Signal vs Grounded Circuit Signal” pg. 22)

### 6. Has NO Polarity

The open circuit signal does not have a polarity therefore the ECT receiver gives no direction indication as to break in the wire. You will need to logically reason the direction of the break in the circuit and then continue to trace it.

### 7. 8 volt amplitude and 4 kilo-Hertz signal

The 4 Kilo-Hertz signal of the open circuit signal can be detected by the SMART receiver. (See: “Locking the Sensitivity for Open Circuits” pg. 14) You can also use the Power Probe III for open circuit signal detection by direct contact. (See: “Verify an Open Circuit” pg. 23)

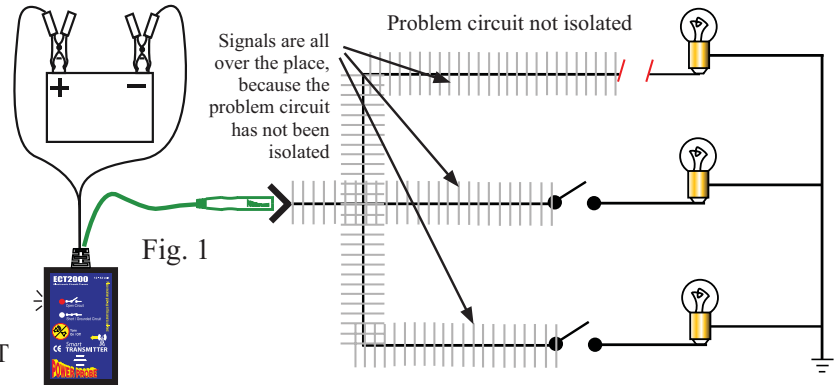

# The SMART Receiver

The SMART receiver is designed to detect the “Grounded Circuit signals” and the open circuit signals from the SMART transmitter.

## Auto shut-off feature

The SMART receiver will automatically shut-off within 30 seconds when it is NOT receiving a signal.

The “**Open & Short Pick-Up**” located on the side of the receiver housing labeled “Open and Short Pick-up” is to sense and detect complete and open circuit signals.

The “**Power/Sensitivity Lock**” button does a few things.

1. It turns the SMART receiver ON and enters “pulse mode” (see “Pulse Mode” pg. 12)
2. It turns the SMART receiver OFF. (providing it is not receiving a signal)
3. It locks the sensitivity of the reception into desired strengths. (see “Locking the Sensitivity” pg. 14)
4. It UN-locks the sensitivity and returns the SMART receiver back to “pulse mode”.

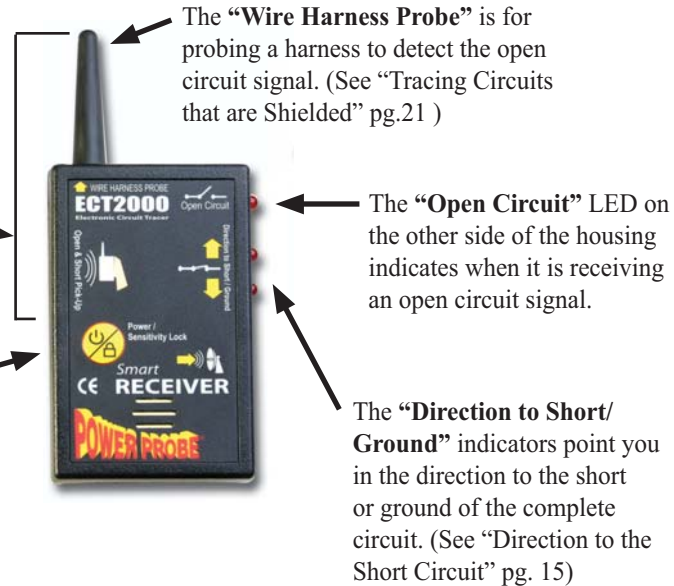

## Battery Installation

1. To install the batteries, remove the battery cover on the back of the housing and insert **(2) AAA batteries** into the battery compartment. Be sure the polarity of the batteries are correct then replace the battery cover.

## Testing the SMART Receiver

To test the SMART receiver, connect the SMART transmitter to the vehicle's battery, turn on the SMART receiver by pressing the "Power/Sensitivity Lock" button. Place the "Open & Short Pick-Up" of the receiver on top of the green signal lead. The SMART receiver should detect the open circuit signal and indicate this by the open circuit LED indicator flashing and pulsing a beeping tone.

To test the SMART receiver for the "short/grounded circuit signal" connect the green signal lead to the negative post of the battery. Then you can test the Grounded Circuit signal by placing the "Open & Short Pick-Up" of the receiver parallel to the green signal lead. The SMART receiver should detect the "Grounded Circuit signal" and show the direction to ground by the "Direction to Short or Ground" indicator.

## Pulse Mode

When you first turn on the SMART receiver it enters into "Pulse Mode". "Pulse Mode" is great for the initial detection of the transmitting signal. You can also get a feel for the strength of the transmitting signal.

As you place the "Open and Short Pick-Up" near an transmitting signal, an LED indicator will blink repeatedly along with an audible beep.

The SMART receiver has 7 sensitivity levels. You can sense each level by observing and listening to the slight increase in pulse frequency as you slowly lower the receiver nearer to the transmitting circuit. The closer you place the "Open and Short Pick-Up" to the transmitting signal, the faster it will pulse. Pulling the receiver away from the transmitting signal it will pulse slower.

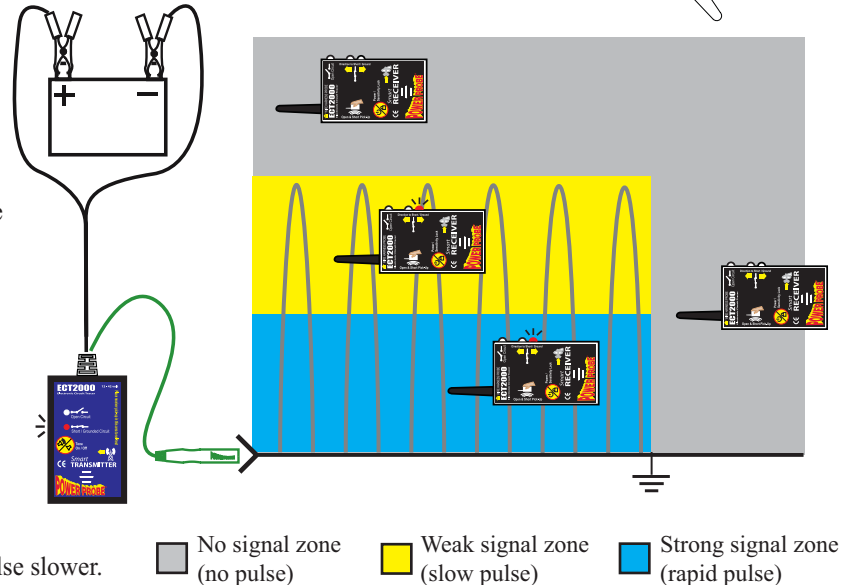
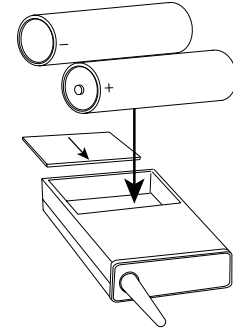

**When the SMART receiver is in “pulse mode”:**

1. It detects both “grounded” and “open” circuit signals.
2. It picks up and determines strong from weak signals by the pulse frequency rate.
3. The sensitivity is ready to be locked in, by pressing the “Power/Sensitivity Lock” button.
4. It detects and displays the direction to ground or a short circuit.

While in “pulse mode” and then pressing the “power/sensitivity lock” button, the SMART receiver’s sensitivity will now be locked and no longer be in “Pulse Mode”. To return to “Pulse Mode” press the “power/sensitivity lock button again.

**The SMART Receiver’s Reception Sensitivity:**

When the SMART receiver is in “pulse mode” you can lower it progressively closer to the transmitting signal and hear the increase in the pulse frequency as it passes each of the 7 sensitivity levels. The fastest pulse frequency is when you are nearest to the transmitting signal. Once you press the “Power/Sensitivity Lock” button the reception sensitivity is locked into that distance (plus/minus a couple of inches) from the transmitting circuit.

**In order to lock the reception sensitivity of the SMART receiver, two conditions must be met.**

1. The SMART receiver must be in “Pulse Mode”.
2. The SMART receiver must be receiving a signal

When these two conditions are met, you can now press the “Power/Sensitivity Lock” button to lock the distance of the SMART receiver and reception sensitivity.

**When the SMART receiver’s reception sensitivity is LOCKED:**

1. The reception sensitivity is held at the distance set.
2. It won’t pick signals farther than the level set.
3. It detects only the type of signal you locked into.

For instance if you are locked into an “open circuit signal”, it will not pick up “Grounded Circuit signals”. If you are locked into a “Grounded Circuit signal” it will not pick up “open circuit signals”.

## Locking the Sensitivity for Short/Grounded Circuits

To lock the SMART receiver's sensitivity for short/grounded circuits, it must be turned on and in "pulse mode". Hold the "Open & Short Pick-Up" of the receiver parallel and as near to the wire as you can while achieving the most rapid pulse rate. (See: Fig. A) Now press the "Power/Sensitivity button". The SMART receiver is now locked into the strong "Grounded Circuit signal" and will ignore weaker parallel circuit signals. If you need to readjust the receiver's sensitivity so that it will pick up weaker circuit signals and be more sensitive, press the "Power/Sensitivity Lock" button to return to "pulse mode". This time, hold the receiver a little farther away from the wire so that the pulse rate is a little slower, and then repress the "Power/Sensitivity Lock" button.

## Locking the Sensitivity for Open Circuits

To adjust the SMART receiver so that it is at its most sensitive setting in open circuit tracing. First turn on the SMART receiver. It is now in "pulse mode". Hold it as close to the open circuit as you can while receiving the most rapid pulse frequency.

Now lift the SMART receiver about 6 inches away from the circuit and press the "Power/Sensitivity Lock" button. (See: Fig. B) At this level you should be able to pick up the open circuit signal in that circuit and eliminate other signals that could be capacitive coupling into neighboring floating circuits and causing you problems. If you need to adjust the SMART receiver so that the reception sensitivity is more sensitive, press the "Power/Sensitivity Lock" button to return to "pulse mode". Now hold the SMART receiver about 8 inches from the transmitting circuit and then press the "Power/Sensitivity Lock" button again. Repeat these steps until you achieve the proper setting for your application.

Fig. A

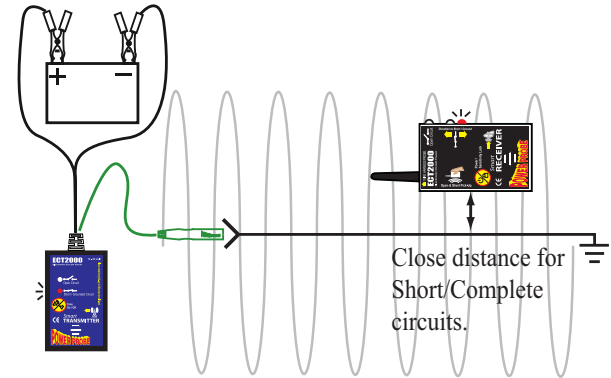
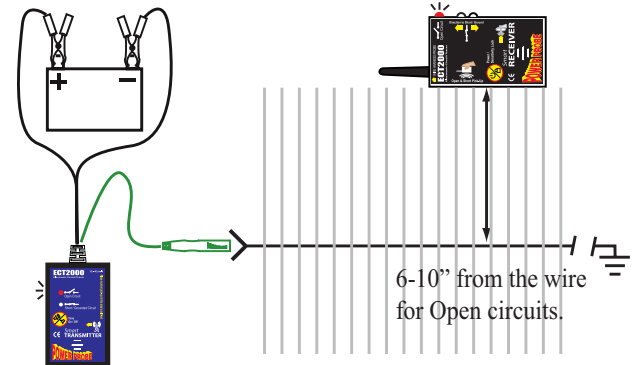

Fig. B



### Direction to the Short

The short/grounded circuit signal is polarized. This gives the SMART receiver the information it needs to show you the direction to the short or the direction to ground. When you place the SMART receiver's "Open & Short Pick-Up" parallel to the wire of the Grounded Circuit signal, "Direction to Short/Ground" indicator will point you in the direction to ground. If you were to flip the SMART receiver in the opposite direction it will detect the polarity change, the "Direction to Short/Ground" indicator will flip, and it will still point you in the direction to ground. Keep in mind that the receiver's "Open & Short Pick-Up" must be held parallel to the circuit for the "Direction to Short/Ground" to indicate.

The ECT 2000 works equally well with either positive chassis ground or negative chassis ground. The only thing you need to keep in mind is, when tracing short circuits the SMART receiver always points you towards the minus of the battery so if you have a short between your wiring and the chassis in a positive ground system, you just need to trace in the opposite direction the LED is pointing!

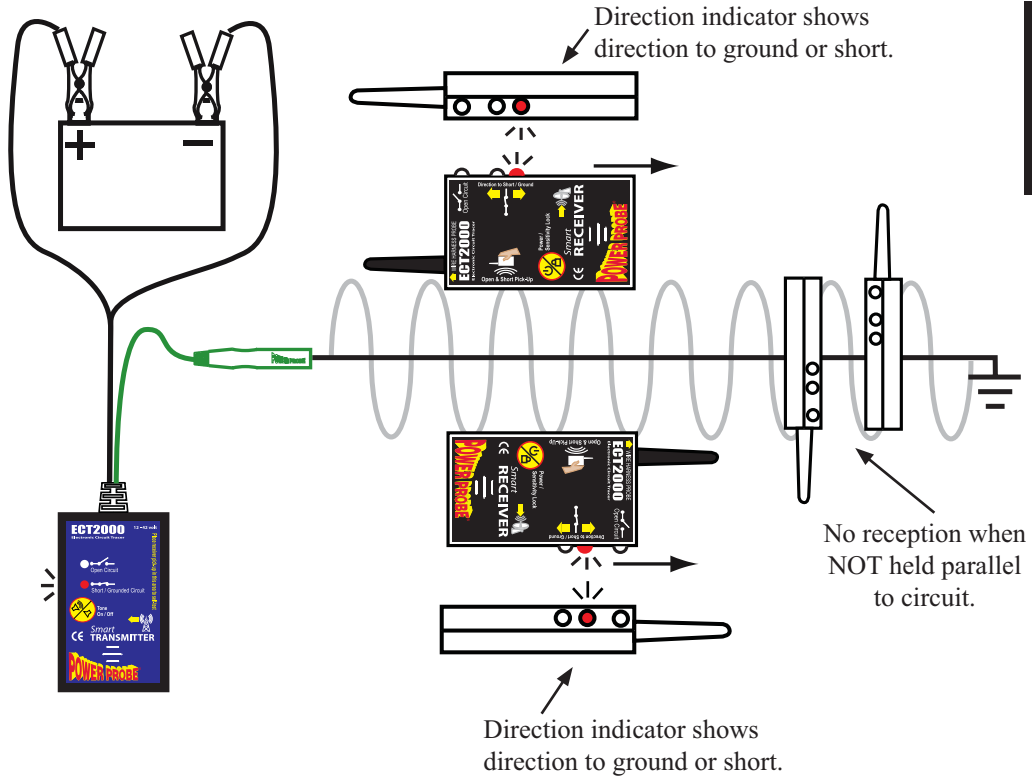

# How to Use the Adapters in Diagnosing Circuits

## Connection Accessories

Included in the ECT-2000 are the following connection accessories.

- Alligator Clip: for connecting onto any conductor such as a wire or a terminal.
- Blade Probe: for tapping into fuse socket terminals and connectors.
- Back Probe: for back probing connectors.
- Piercing Probe: for tapping into wires by piercing through the insulation.
- Light Bulb Socket Adapters: 3 common types for connecting easily to light bulb socket terminals. There are times when the short or open tail or brake light circuit is located nearer to the bulb socket. It is here where you may find it much easier to diagnose the circuit by injecting a signal into the light socket directly.
- Universal Wire Adapter: for making your own custom connector.

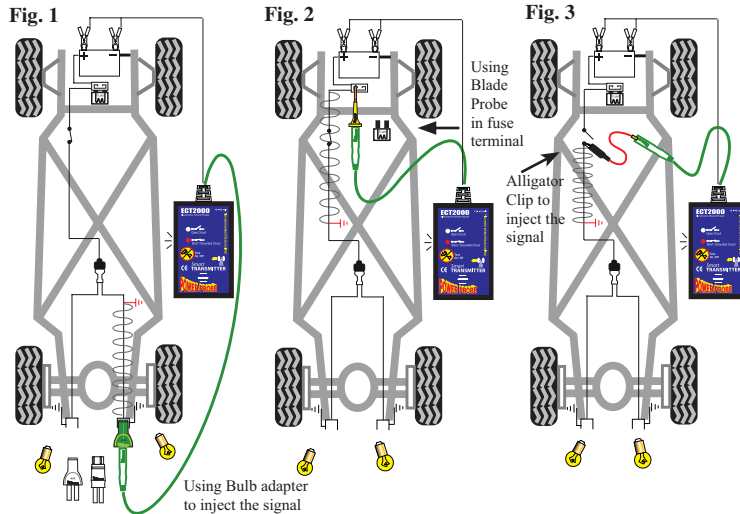
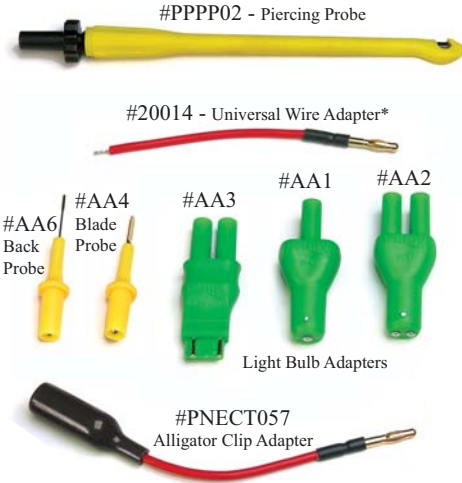

**Fig.1** There are times when a short or open circuit is located closer to the tail light or brake light circuit. It is here where you may find it much easier to diagnose the circuit by injecting a signal into the light socket directly. The bulb socket adapters provide a quick and easy way to connect to bulb socket terminals.

**Fig.2** Other times it maybe necessary to inject the signal at the fuse panel using the flat blade adapter.

**Fig.3** Using the alligator clip adapter on an already exposed wire or the piecing probe are other options.

## How to Trace Out a Short Circuit to Chassis Ground

A direct short to chassis ground that blows a fuse, is one of the simplest circuits to trace for one simple reason. The majority of the “Grounded Circuit Signal” travels THROUGH THE SHORT CIRCUIT TO CHASSIS GROUND making it easy to trace. This sometimes eliminates the need for isolating the circuit.

1. Remove the blown fuse
2. Connect the SMART transmitter’s “power lead” to the vehicles battery
3. Connect the “signal lead” to the shorted terminal of the fuse panel using the Blade probe.
4. Turn on the SMART receiver. It will be in “pulse mode”.
5. Place the “Open & Short Pick-Up” about 2” from the wire harness and parallel to the shorted wire until the “Direction to Short or Ground” indicator beeps rapidly.
6. Press the “Power/Sensitivity Lock” button.
7. Trace the circuit in the direction of the indicator until you loose the signal.
8. If you reach an obstacle remove it or work through it. Remember to ISOLATE THE CIRCUIT YOU ARE TRACING. Inspect the circuit and verify the short. (See: “Verify a short circuit to ground” pg. 18)
9. Isolate the short circuit you are tracing and reconnect the “signal lead directly to the new found part of the shorted wire. (See: “Isolate the Circuit you are Tracing” pg. 18)
10. Continue to follow the signal until you loose it.
11. Inspect the circuit and verify the short.
12. Repeat steps 7 through 10 until you find the cause of the short circuit.
13. Once you fix the short, reconnect all the sections of the circuit you had disconnected earlier.

## Isolate the Circuit You are Tracing

Isolating the circuit you want to trace is absolutely necessary when using “Open Circuit Signals”. It is always good to disconnect the circuit you are tracing away from other parallel circuits. Once you isolate the troubled circuit, you can then connect the SMART transmitter’s signal lead exclusively to your selected circuit. Connecting exclusively to your ISOLATED circuit insures that the SIGNAL is confined in just that one single circuit. The signal strength remains constant throughout the isolated circuit. This makes the circuit easier to trace. You also eliminate confusion of the signal branching off to other areas that will lead you astray. When you are finished diagnosing, don’t forget to reconnect the isolated circuit.

*Isolating a short/grounded circuit is best done by removing the loads in the circuit. This accomplishes two things: 1. It assures that 100% of the signal is being transmitted down the wire you are tracing, 2. if the circuit goes intermittent, the transmitter will alert you. (See: “Circuit Wiggle & Flex Test” pg. 26)*

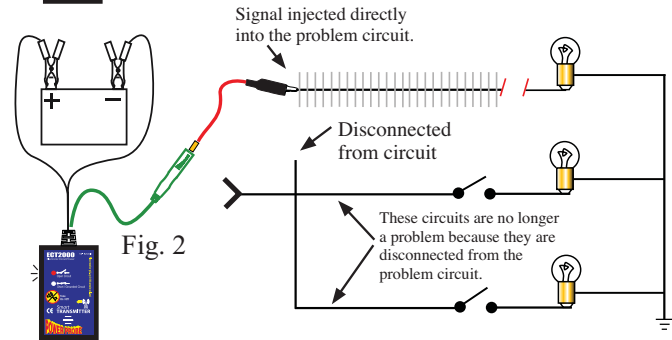
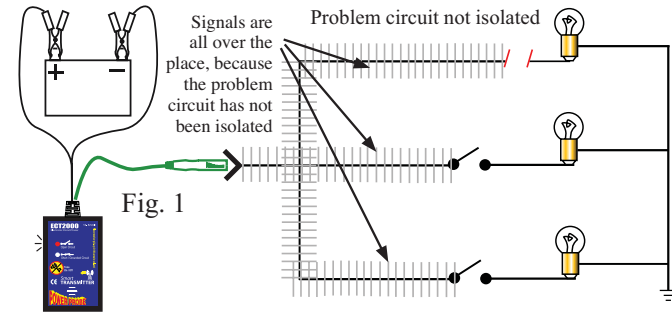

## Verify a Short Circuit to Ground

One of the best tools for verifying a short circuit to ground is the Power Probe 1, 2, or 3. To verify a short circuit connect the Power Probe to the circuit and press the power switch forward. If the Power Probe’s circuit breaker trips, you have verified the short.

*Be careful not to power up circuits that are connected to the vehicles onboard computer. You may have to unplug the computer or electronic modules when performing short circuit verification on electronic systems.*

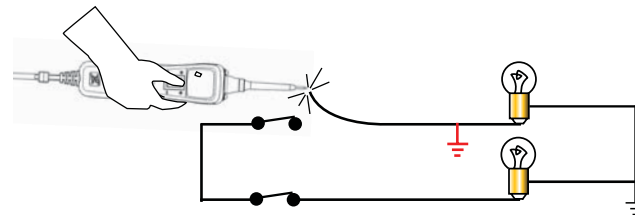

### Short Circuit Inside a Wire Harness

A common occurrence inside of wiring harnesses is that there are two wires running close and parallel to each other. One wire is the positive wire that flows one way and the ground wire that flows back the opposite direction. When the signal source runs closely parallel to the signal return, as in this case, they cancel each other and the signal strength is considerably reduced.

You can pull one wire at a time away from the other wires, creating some distance between them. As you hold the wire away from the other wires, the signal canceling effect is removed in that area and the signal strength will increase in the wire. You can now get a reading off of the wire with the SMART receiver by holding it parallel to the receiver's pick-up area. Take note of the directional indicator of the SMART receiver. Check for the other wire that indicates the opposite direction. You can now assume that both wires are in the same circuit. Trace both wires as a pair along the harness until you find the problem. (see illustration)

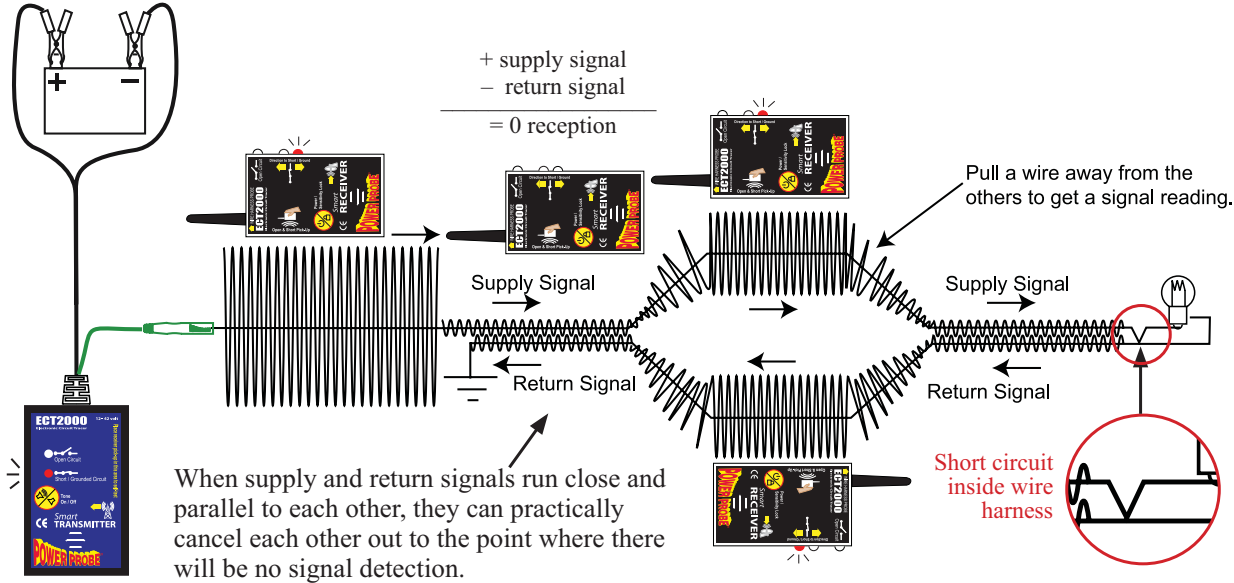

## Reception Distance and What that Means.

When tracing parallel circuits, you can determine if a one wire has a stronger “Grounded Circuit signal” present over another wire. The wire that has a stronger signal carries a larger current. This means the circuit that has the stronger signal also has a lower resistance compared to the other parallel branch. Just knowing this information can come in handy when determining the fault of a circuit.

Once the SMART receiver is locked into the short/grounded circuit signal, (see “Locking the sensitivity of short/grounded circuits”) note the distance of the pick-up area to the wire as you slowly lower it down near to the wire. For example you will notice the SMART receiver’s indicator comes on about 2 inches with one wire and 3 inches with the other wire. The wire that makes the receiver come on 3 inches away is transmitting a stronger signal than the circuit that makes the receiver come on only 2 inches away.

That’s important to know so you can understand and determine which wire has a stronger signal.

This is why it is always recommended to isolate your troubled circuit. Isolating your circuit insures that you are following the correct circuit and it avoids confusion with other parallel wires or circuits.

(See “Isolating the Circuit”pg. 18)

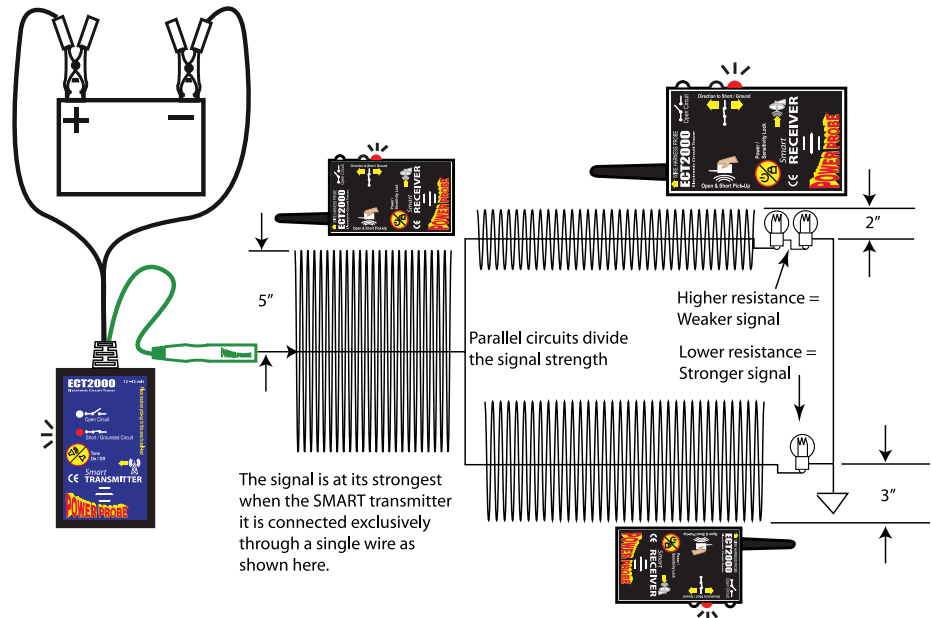

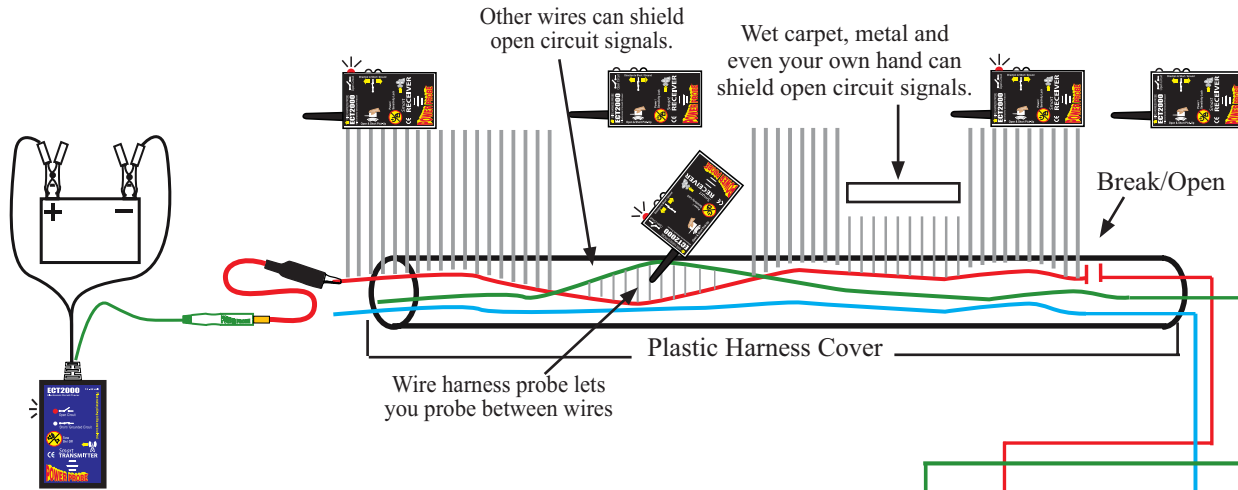

### Tracing Circuits that are Shielded.

Quite often you will need to trace circuits in areas that are shielded from the SMART receiver. This doesn't have to be an impossible feat. Sometimes just a little logic and planning can overcome many obstacles. If your circuit enters a shielded area, consider if it may have an exit point as well. If you receive a signal going into a shielded area and a signal going out, you can consider the problem not in the shielded area. Since you found the exit point of the circuit exposing the wire is unnecessary. If you find that the signal does not exit the shielded area, then you might need to remove the shield and probe further. (See: "Verify an Open Circuit" pg. 23)

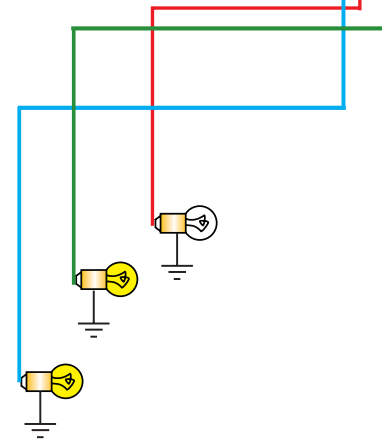

## Open Circuit Signal vs Grounded Circuit Signal

Open circuit signals can only be present in a circuit when there is a resistance of about 100 ohms or greater. (Figure A)

If a switch was to close in this circuit, (Figure B) the open circuit signals would cease to emit and the short/ Grounded Circuit signal would replace it. The SMART transmitter will also sound a tone that tells you that the circuit has just made contact with ground. (Tip: Wiggling and pulling wires that have an open circuit signal on them can lead you to the problem. This is done by the SMART transmitter alerting you if the circuit you are pulling on makes contact to a grounded circuit.) (See: "Circuit Wiggle & Flex Test" pg. 26)

The point here is that Short/Grounded Circuit signals take priority over open circuit signals. So be sure your open circuit that you are tracing does not have any kind of continuity to ground present.

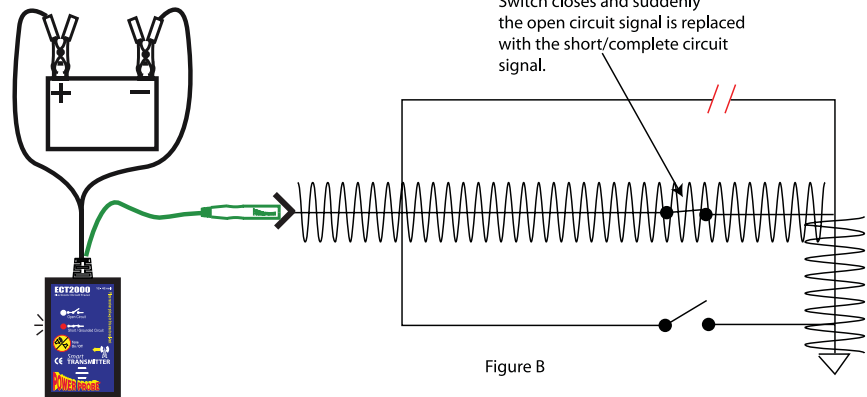
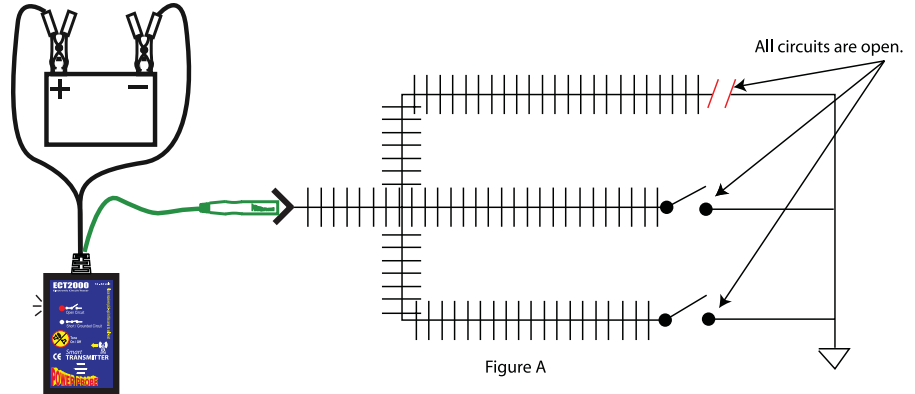

## How to Trace out an Open Circuit:

An open circuit does not complete a path to ground. The cause for an open circuit can vary from an open switch, unplugged connector, bad connections and breaks in wires.

1. Connect the SMART transmitter's power lead to the vehicle's battery.
2. Connect the SMART transmitter's signal lead to the open circuit.
3. Turn on the SMART receiver. It will be in "pulse mode".
4. Place the "Open & Short Pick-Up" near and parallel to the open wire until the "Open Circuit" LED indicator blinks and beeps. (be careful to hold the SMART receiver from the outer edge to prevent your hand from shielding the signal)
5. Lift the SMART receiver away from the open circuit so that the pulse of the "Open Circuit" indicator slows down but doesn't stop completely.
6. Press the "Power/Sensitivity Lock" button.
7. Hold the SMART receiver near to the open circuit and while the "Open Circuit" indicator is ON steady, follow the path of the circuit or wire until you lose the signal.
8. If you reach an obstacle, remove it or work through it. Remember to ISOLATE THE CIRCUIT YOU ARE TRACING. Inspect the circuit and verify the open circuit. (See "Verify an Open Circuit" below.)
9. Continue Steps 7-8 until you find the open or break in the circuit.

## Verify an Open Circuit:

One of the best methods for verifying an open circuit is using the Power Probe III circuit tester together with the SMART transmitter. Since the SMART transmitter's open circuit signal delivers 8 volts and a 4 kHz signal, it can be easily detected by directly contacting the Power Probe III to the wire of the transmitting circuit.

Contact the probe of the Power Probe III to the open circuit with the open circuit signal applied to it. You should hear the 4 kHz tone from the Power Probe III speaker. If you don't hear the 4 kHz tone, inspect the circuit closer to determine why? If you hear the 4 kHz tone, you are on the correct circuit. Testing the open circuit with SMART transmitter together with the PP3 has advantages over just a continuity test. This is because the SMART transmitter's toggle tone feature will alert you if the open circuit makes contact with an intermittent grounded circuit. (See: "Circuit Wiggle & Flex Test" pg. 26)

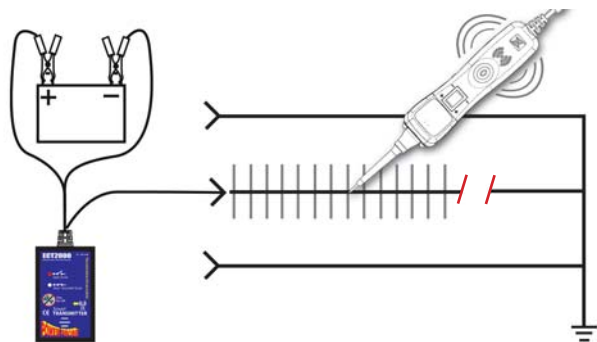

## Bench Tracing a Wire Harness

There are cases where you may have a wire harness removed from the vehicle, sitting on the bench, and tracing an open circuit. Wire harnesses that are removed from the vehicle's electrical system have only floating wires in them. The open connectors of the harness are connected neither to positive nor negative therefore all of the harness's circuits are open and floating. It is important to be aware that the open circuit signal will capacitive couple into floating circuits that run parallel and next to the transmitting signal wire. (See Figure A). Floating circuits that couple the open circuit signal also transmit the signal too and will even couple back to the wire you want to trace. This prevents the SMART receiver from locating the break in the wire because all the wires are transmitting signals. You can be easily led down the wrong circuit if you are not aware of this.

To correct this problem, you need to tie all parallel floating open circuits to either ground or a positive voltage (see Figure B). All neighboring wires and circuits must have some potential of ground or positive on them to prevent capacitive coupling from occurring.

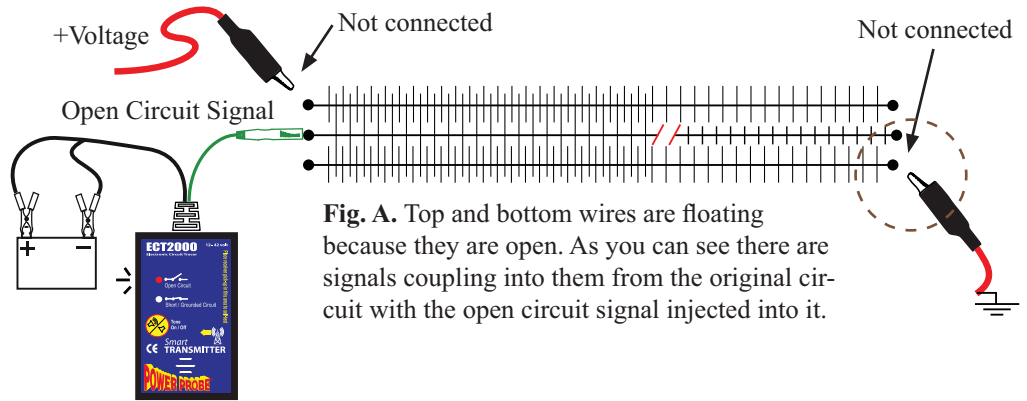

**Fig. A.** Top and bottom wires are floating because they are open. As you can see there are signals coupling into them from the original circuit with the open circuit signal injected into it.

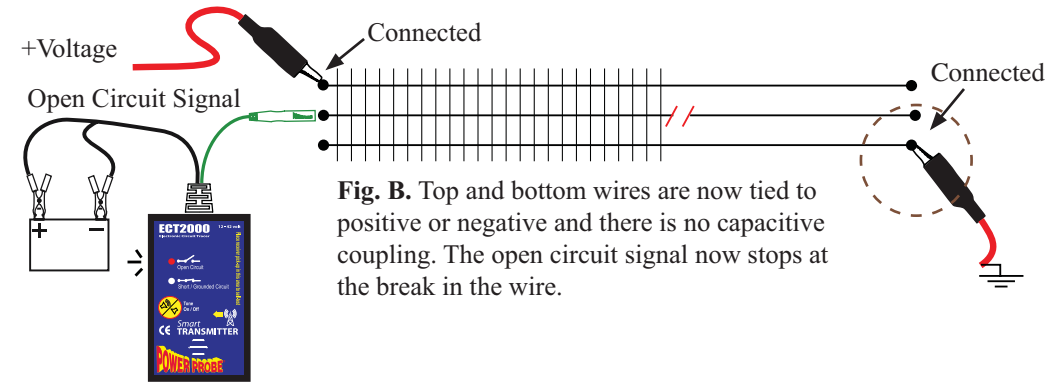

**Fig. B.** Top and bottom wires are now tied to positive or negative and there is no capacitive coupling. The open circuit signal now stops at the break in the wire.

*It is recommended to trace OPEN circuits while the IGNITION is turned ON. This will supply a positive voltage on certain circuits that can potentially capacitive couple. It is also a good idea to keep all of the vehicle's electrical loads (light bulbs, relays, motors, etc.) CONNECTED while tracing OPEN circuits. This keeps certain neighboring circuits grounded, which also prevents them from capacitive coupling.*

## Tracing out Battery Drains or Current Draw

When you have a battery or current draw that is drawing enough current to drain the battery over night or a couple of days, you have a condition that the SMART ECT-2000 can assist you in. In cases like this you can inject a signal into the main positive battery cable after removing it from the positive battery post. Now you can follow the signal along its path and look for the possible cause of the battery drain.

Tracing battery drains are a little different than tracing a short or open circuit. When you are tracing battery drains you are not looking for a loss of signal, you are simply following the circuit path and unplugging wires and components along the way to give you clues to the problem.

To trace battery drains and get nearer to the location of the current draw:

1. Disconnect the positive terminal from the vehicle's battery. (You will need to consult your vehicle's owner manual for proper battery disconnecting instruction. Some vehicles require that voltage potential be maintained at all times on certain components for instance, radios, onboard computers, memory, CPUs, etc.)
2. Connect the SMART transmitter's 20ft power lead to the positive and negative post of the battery.
3. Connect the signal lead to the disconnected positive terminal. Trace the circuit that is transmitting the strong signal with the SMART receiver. (The directional indicators only show you the direction to ground. It will not stop at the fault.)
4. Disconnect the wire and components along the circuit path to narrow down the cause of the current draw.

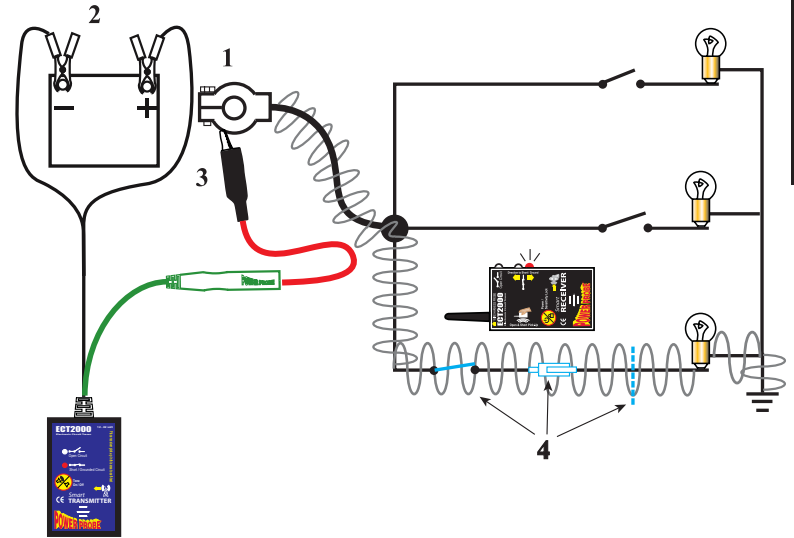

## Circuit wiggle & flex test

At times it's necessary to check for intermittent connection problems. The circuit wiggle test allows you to wiggle, twist, pull, push and flex wires or connectors and observe a circuit change. The SMART transmitter monitors the condition of the circuit and alerts you to a change.

For instance, if you are injecting an open circuit signal into an open circuit and you wiggle the wires, it might make contact inside of a broken wire or a loose connector. The SMART transmitter will sound off at the instant the open circuit makes contact with a connection or ground. At this point you can keep flexing and wiggling the wire to locate the problem.

If you are injecting an isolated Grounded Circuit and the wires you wiggle causes it to lose contact, it will instantly sound-off, alerting you to the fact that the circuit has lost its connection to ground.

As the SMART transmitter is sounding, you can press the "Tone On/Off" button and the tone will toggle off. When you toggle it off, as it is alerting you to an open circuit, it now silently monitors the open circuit until it makes contact with ground again.

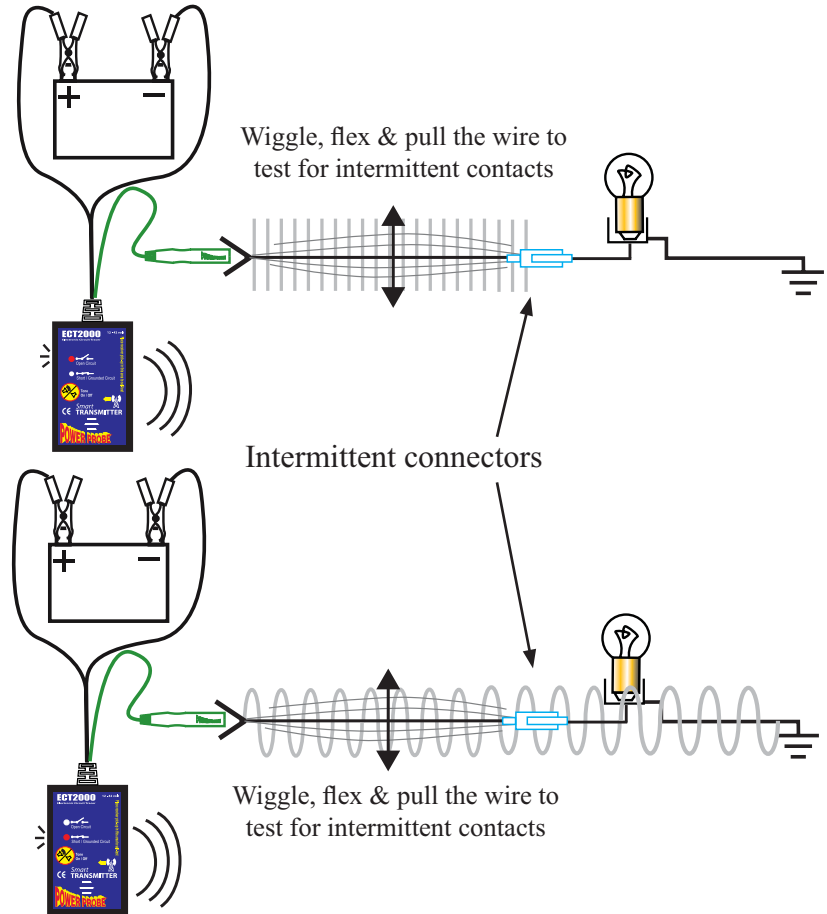

	page
4 KHz polarized signal.....	8
accessories.....	16
adapters.....	16
applications of adapters.....	16
battery drains.....	25
battery draws.....	25
battery replacement.....	11
complete circuit signal.....	7 & 8
current draws.....	25
direction to short/ground indicator.....	11
direction to short/ground indicator.....	15
divided circuit.....	20
e-field.....	9
flex test.....	26
floating circuits.....	24
hook-up.....	6
intermittent circuit.....	26
isolate the circuit.....	18
least resistance.....	8
lock reception condition.....	13
open & short pick-up.....	11
open circuit indicator LED.....	11
open circuit signal.....	7
open circuit signal.....	9 & 10
open vs complete signal.....	22
parallel circuits.....	10
parts.....	5

	page
power lead.....	6
power/sensitivity lock.....	11
pulse mode.....	12
reception distance.....	20
reception sensitivity.....	13
self test.....	6
sensitivity locking.....	14
shielding.....	9
shielding.....	21
short circuit inside harness.....	19
signal canceling.....	19
signal lead.....	6
SMART receiver.....	11
testing the SMART receiver.....	12
tone on/off.....	6
tracing a short circuit.....	17
tracing an open circuit.....	23
transmitter.....	5
transmitter current.....	8
transmitter frequency.....	8
transmitter frequency.....	10
transmitter voltage.....	10
verify a short.....	18
verify an open circuit.....	23
wiggle test.....	26
wire harness probe.....	11

# Index

This product has been certified for EMC (Electro-Magnetic Compatibility) compliance