

Name _____

MULTIPLE CHOICE. Choose the one alternative that best completes the statement or answers the question.

1) Which first digit code indicates a network fault? 1) _____

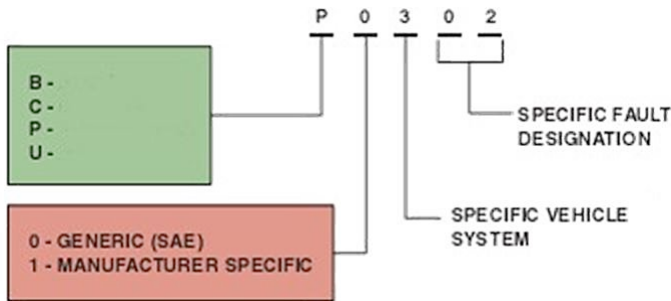

- A) U
- B) B
- C) P
- D) C

2) Parameter identification (PID) is included in which OBD-II generic mode? 2) _____

- A) Mode one
- B) Mode two
- C) Mode four
- D) Mode eight

3) Permanent diagnostic trouble codes (DTCs) _____. 3) _____

- A) Can be erased using a factory-level scan tool
- B) Can be erased using a global (generic) scan tool
- C) Cannot be erased
- D) Either A or B

4) OBD II has been on all passenger vehicles in the United States since _____. 4) _____

- A) 1986
- B) 1991
- C) 1996
- D) 2000

5) Which of these is NOT stored when a freeze-frame is recorded? 5) _____

- A) Engine RPM
- B) Vehicle speed
- C) Coolant temperature
- D) Air conditioner ON or OFF

- 6) The test that checks to see that the information is plausible is called _____. 6) _____
A) Functionality
B) Rationality
C) Shorts-to-ground
D) All of the above
- 7) Which of these is NOT a goal of OBD-II equipped vehicles? 7) _____
A) Detect faulty emission-related systems
B) Put the vehicle into "limp home" mode if a fault is detected
C) Alert the driver of emission-related faults
D) Allow the use of generic scan tools
- 8) The computer will automatically clear a DTC if there are no additional detected faults after _____. 8) _____
A) 40 consecutive warm-up cycles
B) 80 warm-up cycles
C) Two consecutive trips
D) All of the above
- 9) Technician A says that "U" codes can be ignored until after the vehicle is repaired. Technician B says that "U" codes should be diagnosed first. Which technician is correct? 9) _____
A) Technician A only
B) Technician B only
C) Both technicians A and B
D) Neither technician A nor B
- 10) When is a freeze-frame generated on an OBD-II-equipped vehicle? 10) _____
A) When a type C or D diagnostic trouble code is set
B) When a type A or type B diagnostic trouble code is set
C) Every other trip
D) When the PCM detects a problem with the O2S

Answer Key

Testname: LVDE1_19A

1) A

Page Ref: 224

2) A

Page Ref: 226

3) C

Page Ref: 225

4) C

Page Ref: 226

5) D

Page Ref: 226

6) B

Page Ref: 226

7) B

Page Ref: 222

8) A

Page Ref: 226

9) B

Page Ref: 225

10) B

Page Ref: 225