

Name \_\_\_\_\_

**MULTIPLE CHOICE. Choose the one alternative that best completes the statement or answers the question.**

- 1) The comprehensive component monitor checks computer controlled devices for \_\_\_\_\_. 1) \_\_\_\_\_  
 A) Opens  
 B) Rationality  
 C) Shorts-to-ground  
 D) All of the above

- 2) Which first digit code indicates a network fault? 2) \_\_\_\_\_

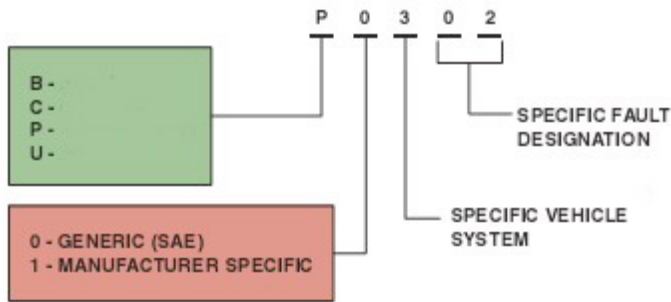

- A) U  
 B) B  
 C) C  
 D) P

- 3) A pending code is set when a fault is detected on \_\_\_\_\_. 3) \_\_\_\_\_  
 A) A one trip fault item  
 B) The first fault of a two-trip failure  
 C) The catalytic converter efficiency  
 D) Thermostat problem (too long to closed-loop status)

- 4) An ignition misfire or fuel mixture problem is an example of what type of DTC? 4) \_\_\_\_\_  
 A) Type A  
 B) Type B  
 C) Type C  
 D) Type D

- 5) Which of these is a continuous monitor? 5) \_\_\_\_\_  
 A) Fuel system monitor  
 B) EGR monitor  
 C) Oxygen sensor monitor  
 D) Catalyst monitor

- 6) DTC P0302 is a \_\_\_\_\_. 6) \_\_\_\_\_  
 A) Generic DTC  
 B) Manufacturer specific DTC  
 C) Idle speed related DTC  
 D) Transmission/transaxle DTC

- 7) A vehicle has stored a DTC for an oxygen sensor fault. This could cause \_\_\_\_\_. 7) \_\_\_\_\_
- A) A no start condition
  - B) The catalyst monitor to not run
  - C) Third gear only
  - D) An inoperative AC system
- 8) A generic scan tool can access the same freeze frame information as an enhanced original equipment manufacturer's scan tool 8) \_\_\_\_\_
- A) True
  - B) False
- 9) Global (generic) OBD II contains some data in what format? 9) \_\_\_\_\_
- A) Plain English
  - B) Hexadecimal
  - C) Roman numerals
  - D) All of the above
- 10) OBD-II has been on all passenger cars in the United States since \_\_\_\_\_. 10) \_\_\_\_\_
- A) 1986
  - B) 1991
  - C) 1996
  - D) 2000

## Answer Key

Testname: ENGINEPERF5\_19B

1) D

Page Ref: 323

2) A

Page Ref: 326

3) B

Page Ref: 327

4) A

Page Ref: 326

5) A

Page Ref: 324

6) A

Page Ref: 326

7) B

Page Ref: 328

8) B

Page Ref: 327

9) B

Page Ref: 329

10) C

Page Ref: 321