

A9 Part ID Worksheet Pressure Sensing Glow Plug

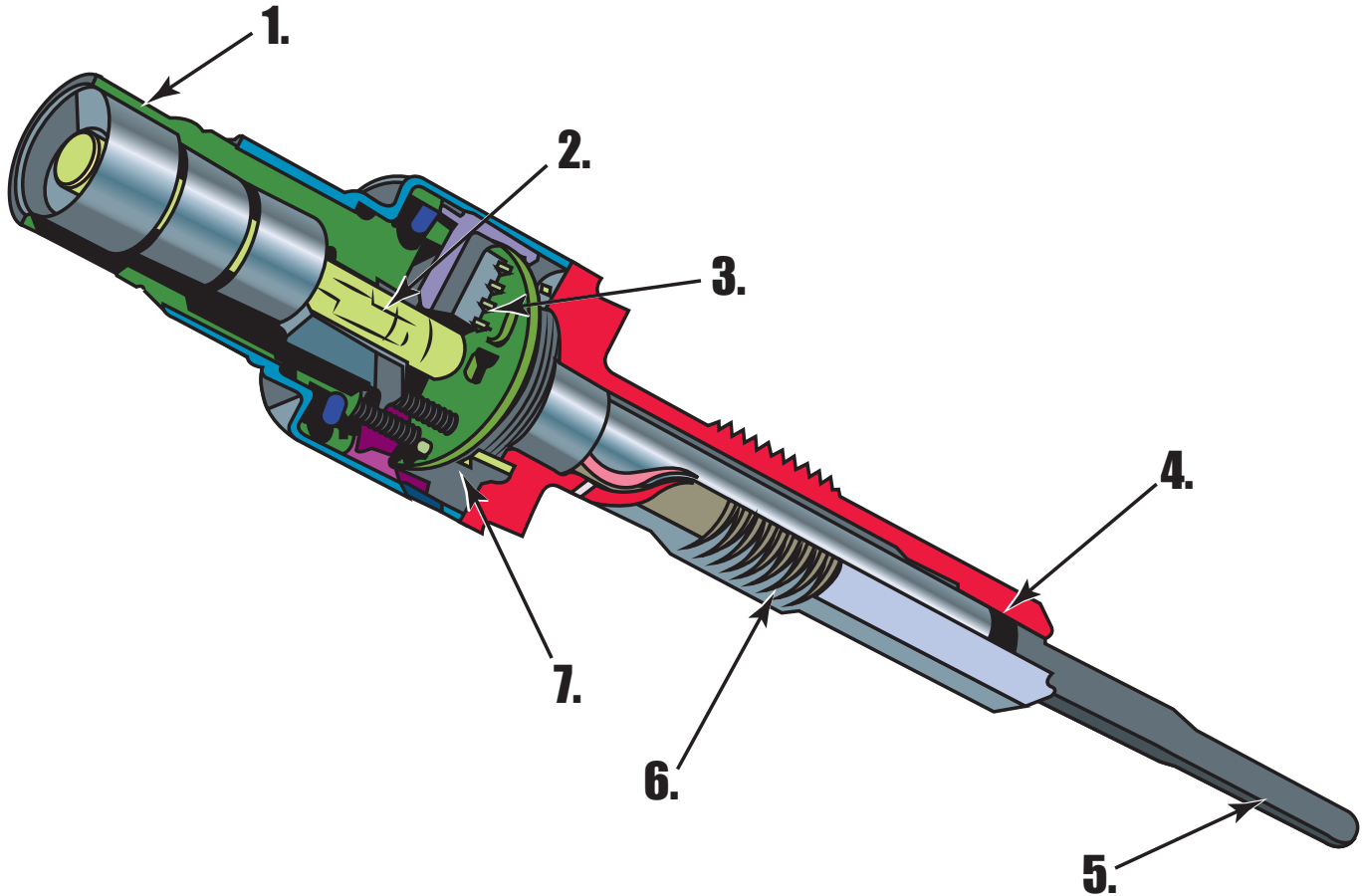

1. _____
PLUG

2. _____
HIGH CURRENT CONNECTION

3. _____
PRINTED CIRCUIT BOARD WITH
ELECTRONICS

4. _____
SEAL

5. _____
GLOW PLUG HEATING ROD

6. _____
GLOW PLUG BODY

7. _____
MEASURING DIAPHRAGM

A9 Part ID Worksheet Turbocharger

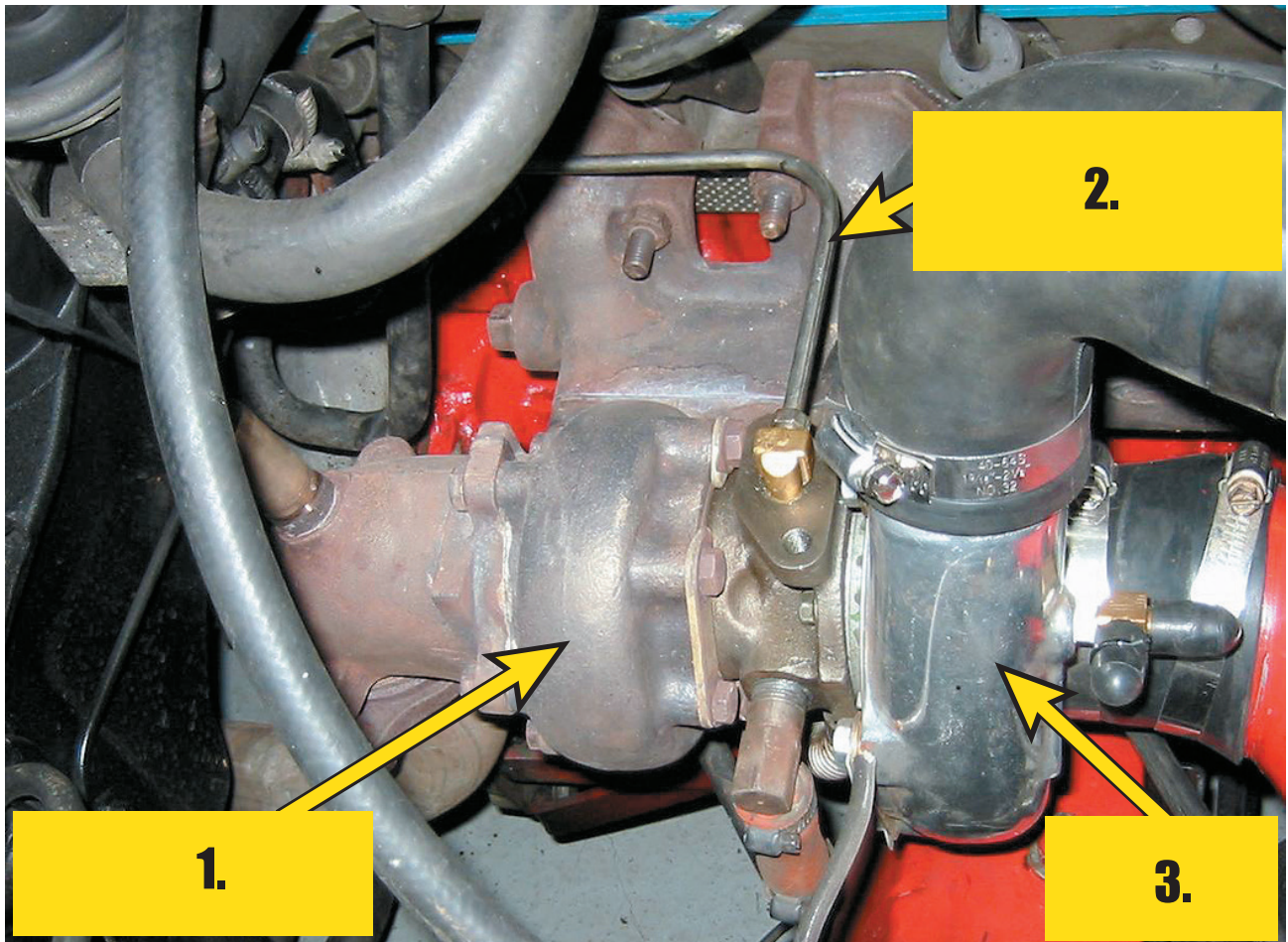

- 1.** TURBINE (EXHAUST SIDE)
- 2.** OIL LINE TO TURBOCHARGER BUSHINGS
- 3.** IMPELLER (AIR SIDE)

A9 Part ID Worksheet Injector Pump

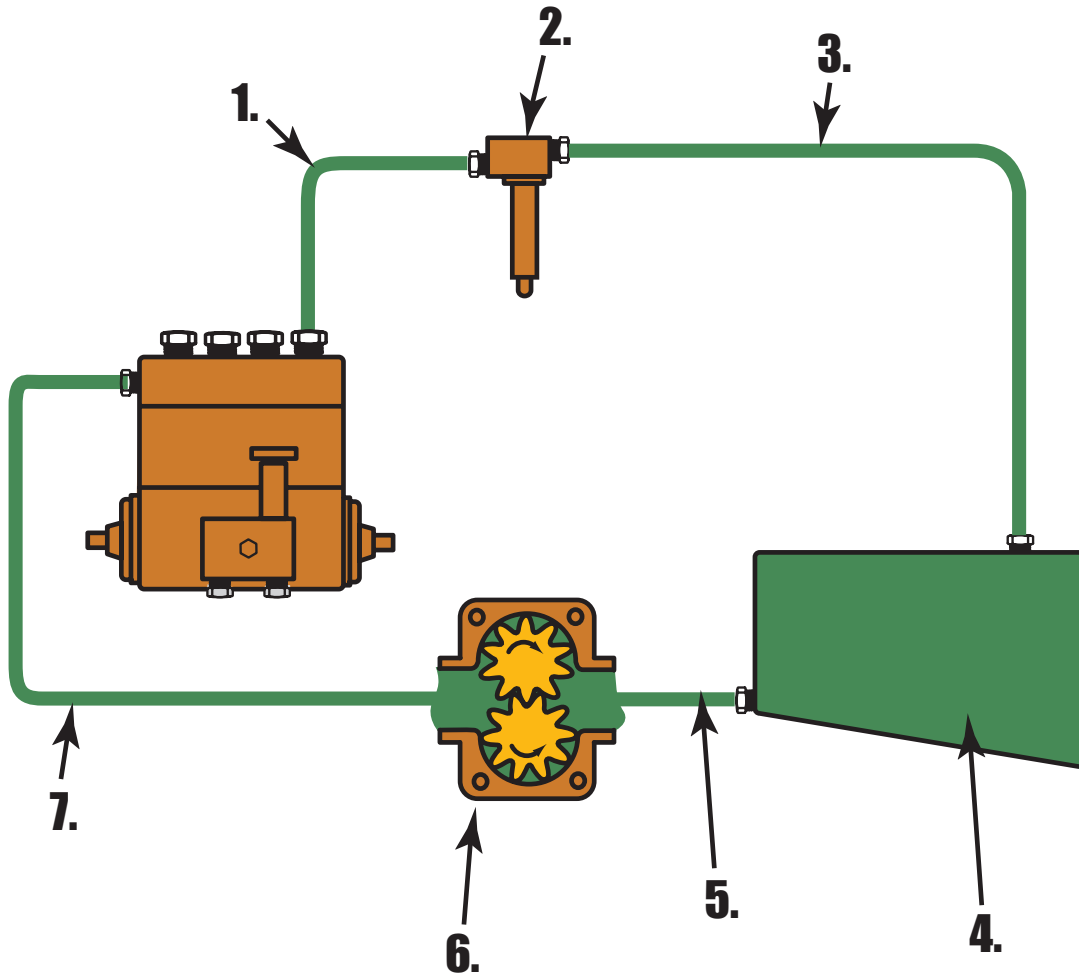

1. INJECTOR LINE

2. INJECTOR

3. RETURN LINE

4. FUEL TANK

5. SUPPLY LINE

6. TRANSFER PUMP

7. INLET LINE

A9 Part ID Worksheet Valve

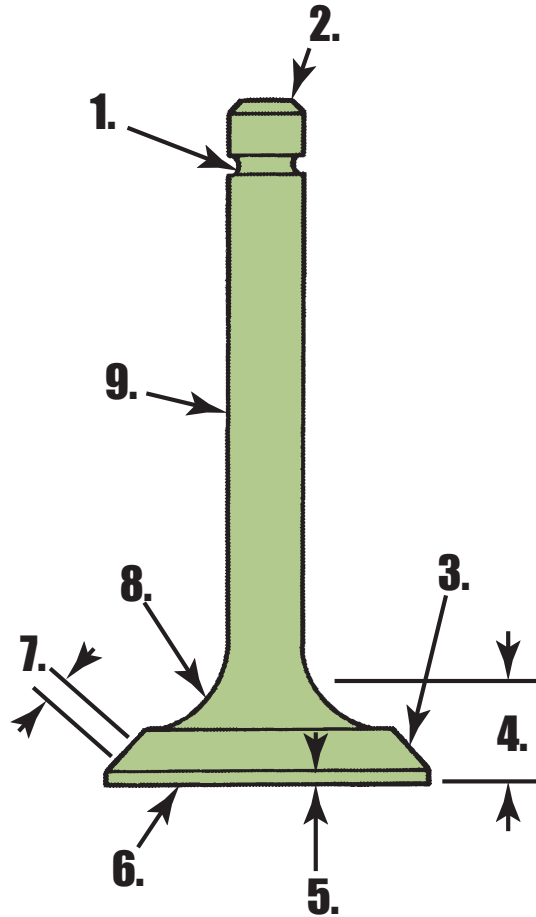

1. KEEPER GROOVE

2. VALVE TIP

3. VALVE FACE

4. VALVE HEAD

5. MARGIN

6. COMBUSTION SURFACE

7. PROPER SEAT CONTACT AREA

8. STEM

9. FILLET

A9 Part ID Worksheet Variable Vane Turbocharger

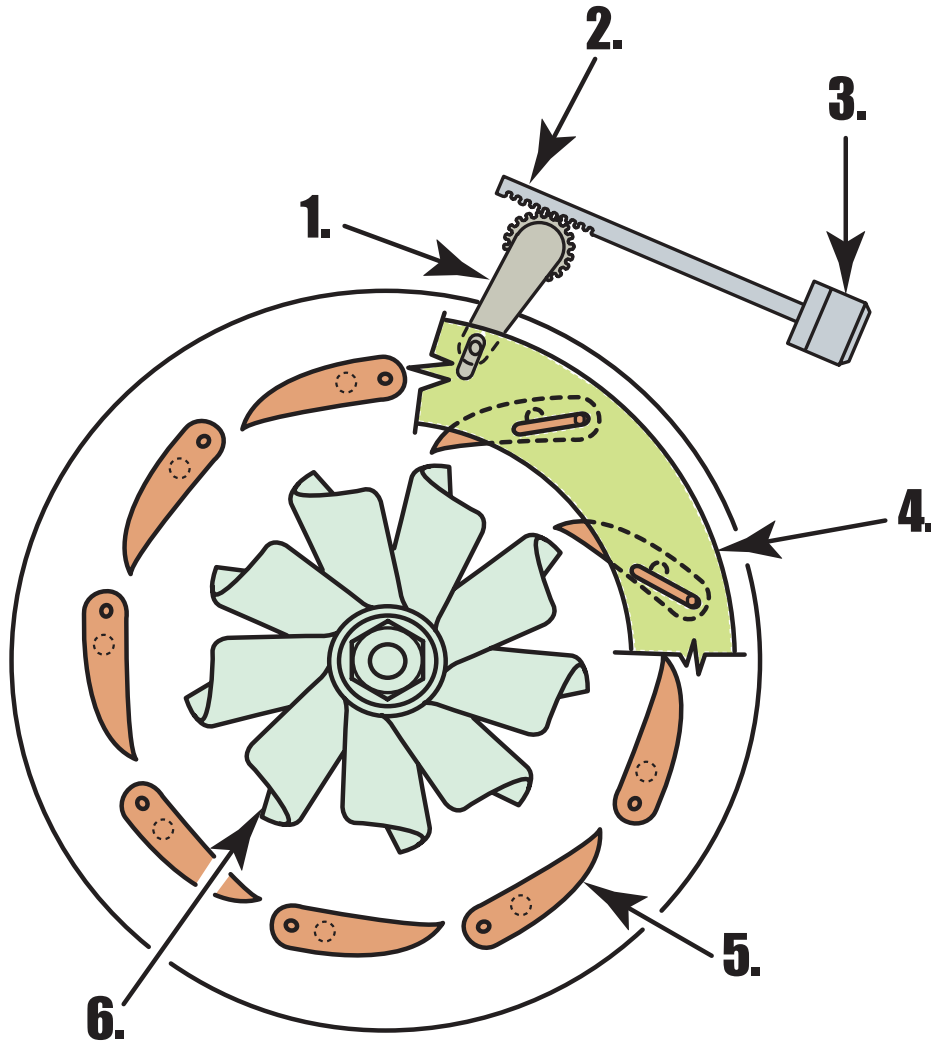

1. _____ CAM

2. _____ RACK

3. _____ HYDRAULIC PISTON

4. _____ UNISON RING

5. _____ ADJUSTABLE VANES

6. _____ TURBINE