

## A1 Part ID Worksheet EGR Valve

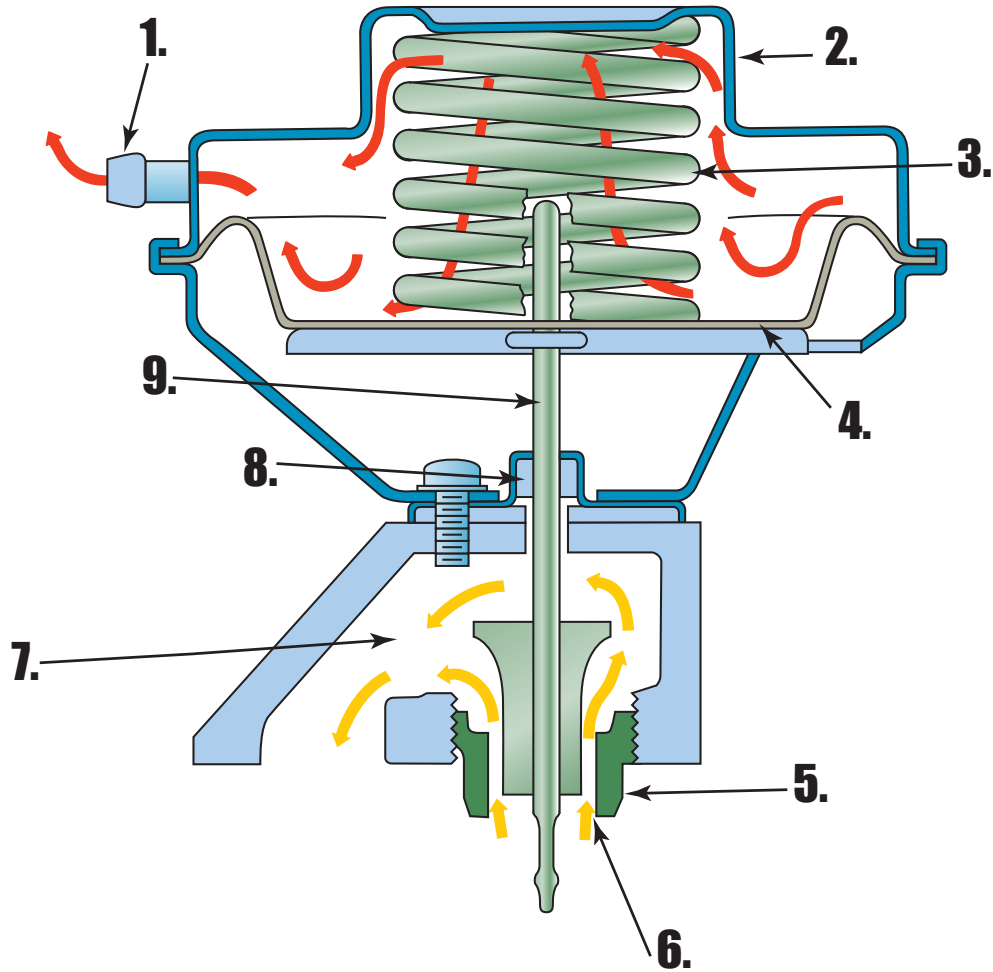

1. CONTROLLED VACUUM CONNECTION  
\_\_\_\_\_

2. DIAPHRAGM COVER  
\_\_\_\_\_

3. SPRING  
\_\_\_\_\_

4. ACTUATING DIAPHRAGM  
\_\_\_\_\_

5. VALVE SEAT  
\_\_\_\_\_

6. EXHAUST GAS INLET  
\_\_\_\_\_

7. VALVE CHAMBER  
\_\_\_\_\_

8. SEAL  
\_\_\_\_\_

9. VALVE SHAFT  
\_\_\_\_\_

## A1 Part ID Worksheet Engine Configurations

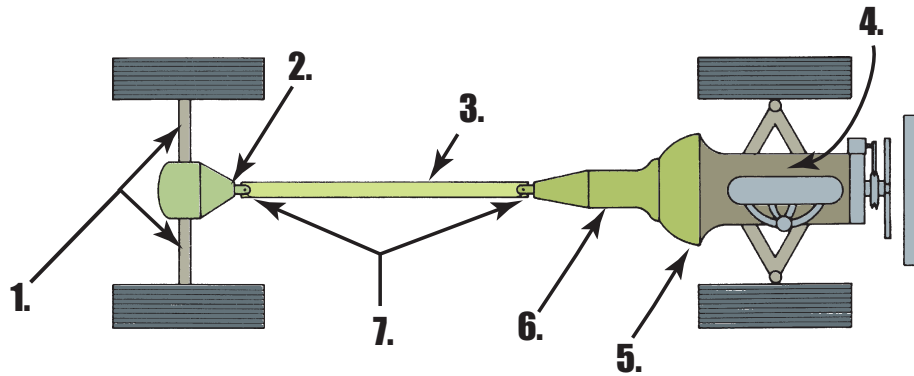

A longitudinally mounted engine.

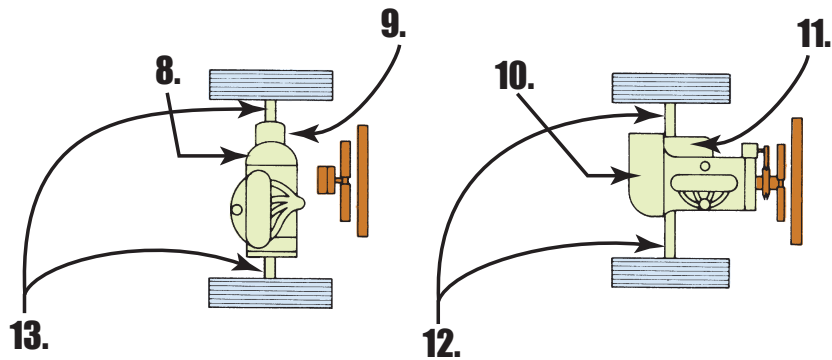

Two types of front-engine, front-wheel drive mountings.

1. REAR AXLES

2. DIFFERENTIAL  
PROPELLER SHAFT OR  
DRIVESHAFT

4. ENGINE  
CLUTCH OR TORQUE  
CONVERTER

6. TRANSMISSION

7. UNIVERSAL JOINTS

8. CLUTCH OR TORQUE  
CONVERTER

9. TRANSAXLE  
CLUTCH OR TORQUE  
CONVERTER

10. TRANSMISSION AND  
DIFFERENTIAL

12. HALF SHAFTS

13. HALF SHAFTS

Name: \_\_\_\_\_

## A1 Part ID Worksheet Hydraulic Lifter

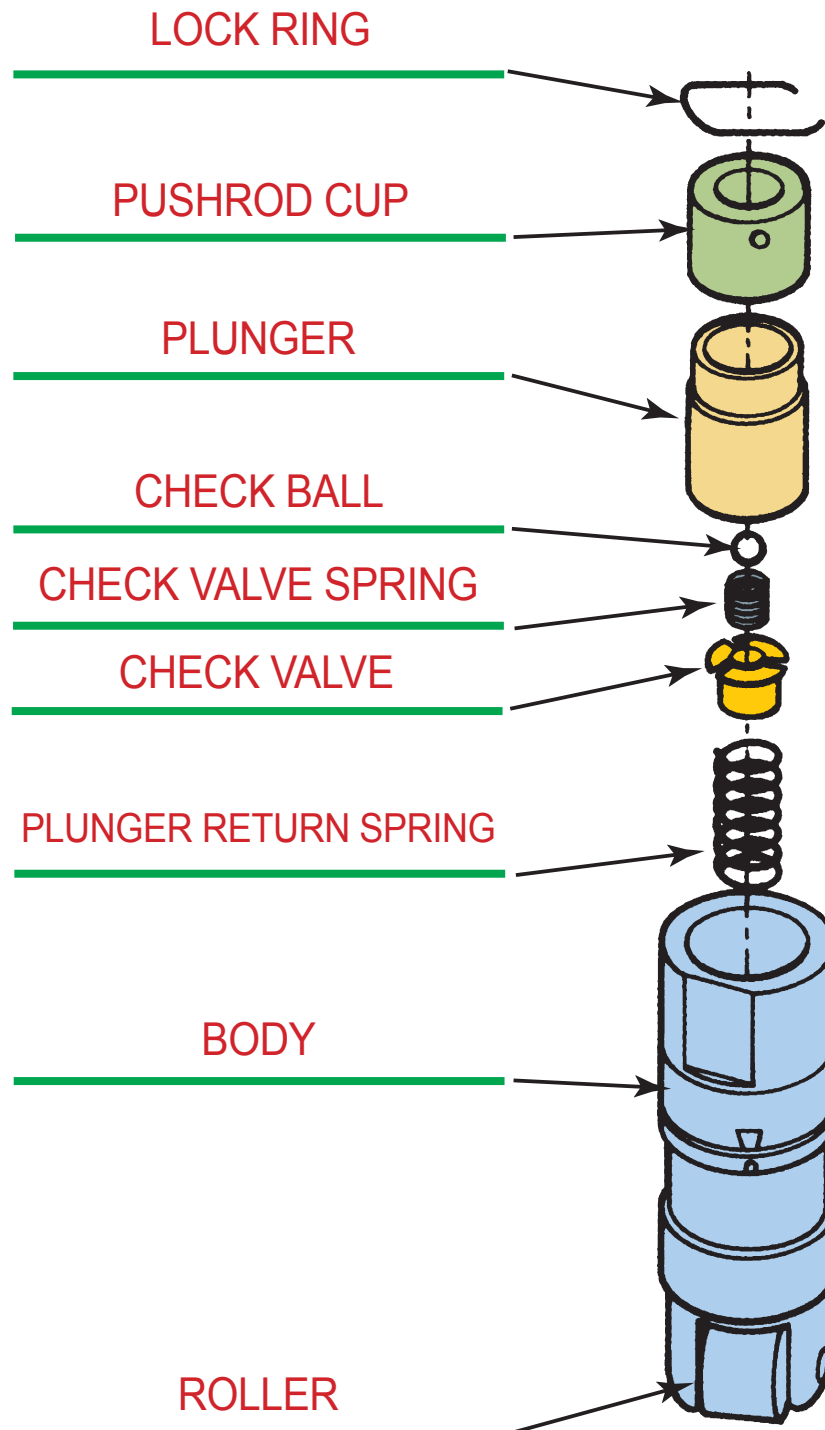

## A1 Part ID Worksheet Micrometer

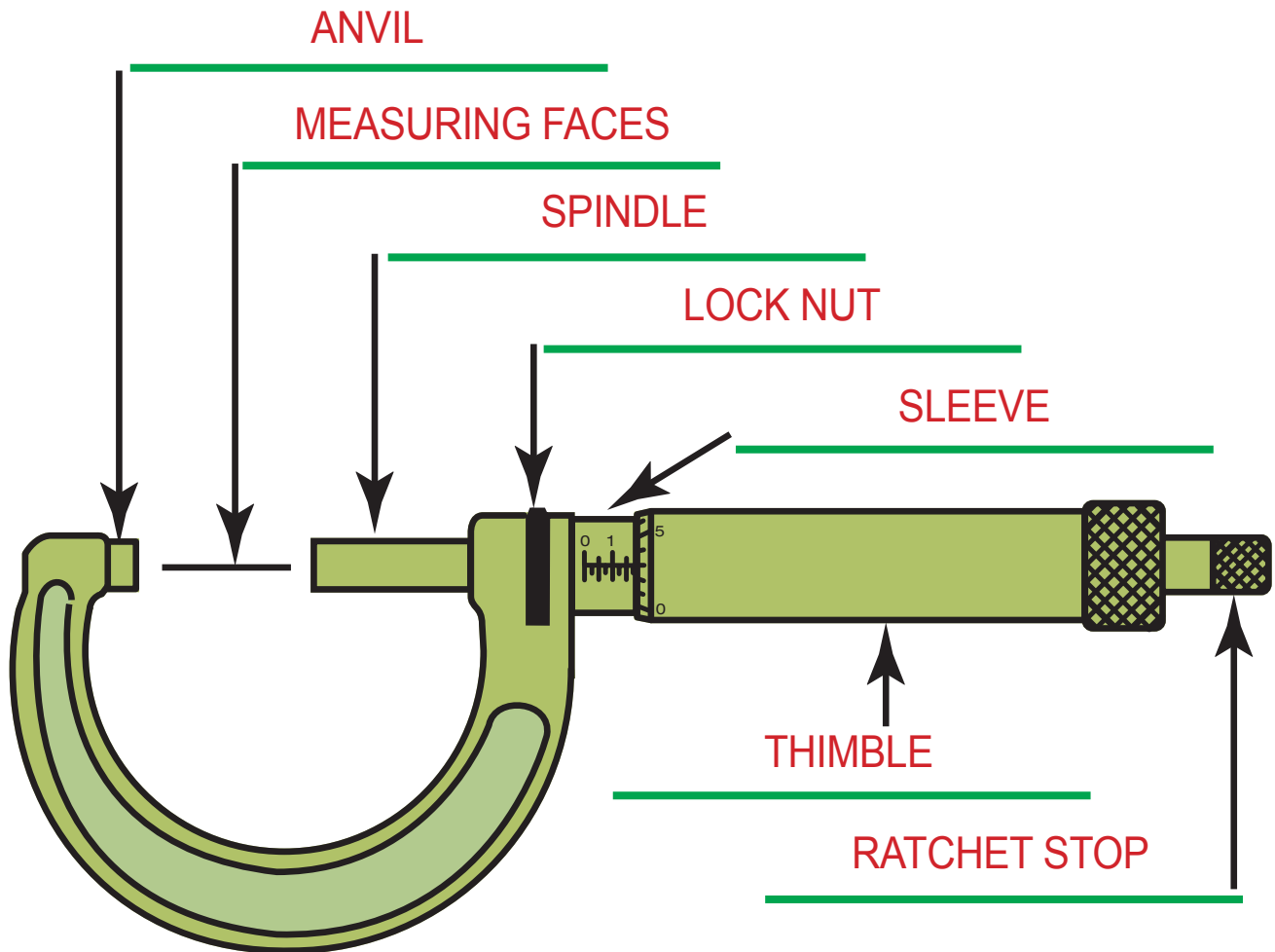

## A1 Part ID Worksheet Piston

