

Starter Voltage Drop/Current Draw Tests

Meets ASE Task: (A6-C-1) P-1, (A6-C-2) P-1, and (A6-C-6) P-2 Perform starter current draw tests; determine necessary action.

Name _____ Date _____ Time on Task _____

Make/Model/Year _____ VIN _____ Evaluation: 4 3 2 1

- _____ 1. Check service information for the specified starter current draw test procedure and specifications.

NOTE: Few vehicle manufacturers give starter current draw specifications with the starter installed on the vehicle. Use the chart below as a guideline regarding the range of the maximum allowable starter draw.

4-cylinder engines = 150 to 185 amperes maximum (normally less than 100 A)

6-cylinder engines = 160 to 200 amperes maximum (normally less than 125 A)

8-cylinder engines = 185 to 250 amperes maximum (normally less than 150 A)

- _____ 2. Perform the starter current draw test following the manufacturer's instructions.

Results: _____ amperes

- _____ 3. Connect the voltmeter, as shown in the illustration, and crank the engine. Observe the voltmeter.

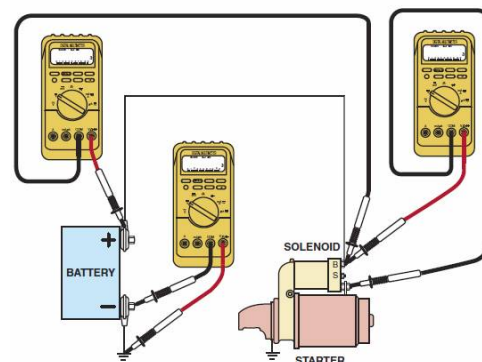

- _____ 4. All test results should be less than 0.2 V (200 mV).

- _____ 5. Based on the specifications and the test results, what is the necessary action?
