

Driver Information and Warning Devices

Meets ASE Task: (A6-F-2) P-2 Inspect and test connectors, wires, and printed circuit boards of gauge circuits; determine necessary action.

Name _____ Date _____ Time on Task _____

Make/Model/Year _____ VIN _____ Evaluation: 4 3 2 1

_____ 1. Check service information for the specified testing procedures to test the gauge printed circuit boards, and diagnosis of warning devices. _____

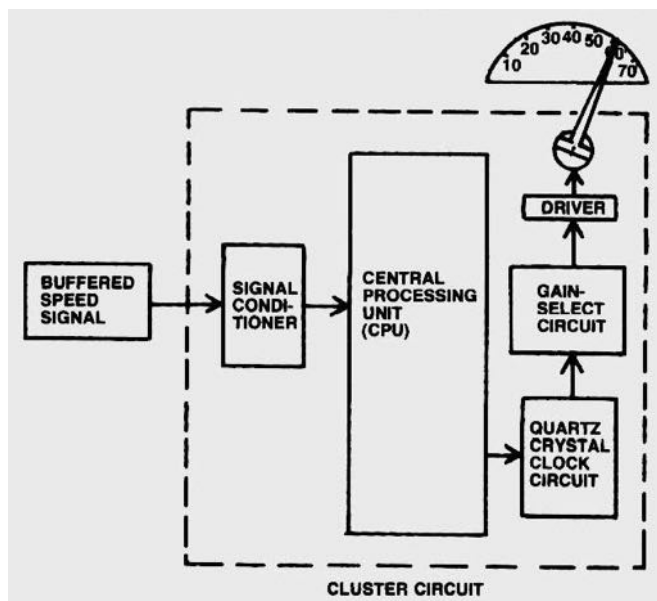

_____ 2. Perform a visual inspection of the wires and connectors to the printed circuit boards.

_____ **OK**

_____ **NOT OK** (describe fault) _____

_____ 3. Visually check the gauge printed circuit boards for discoloration or poor solder joints.

_____ **OK**

_____ **NOT OK**

_____ 4. Based on the tests and inspection, what is the needed action? _____