

Battery Charging

Meets ASE Task: (A6-B-5) P-1 Perform slow/fast battery charge.

Name _____ Date _____ Time on Task _____

Make/Model/Year _____ VIN _____ Evaluation: 4 3 2 1

_____ 1. Measure the open-circuit voltage of the battery = _____ volts (red lead of the voltmeter to positive [+] and black lead to negative [-]). (If more than 12.6 V, remove the surface charge by turning on the headlights for 1 minute).

_____ 2. Percentage of charge = _____ %.

- 12.6 V or higher = 100% charged
- 12.4 V = 75% charged
- 12.2 V = 50% charged
- 12.0 V = 25% charged
- below 11.9 V = discharged

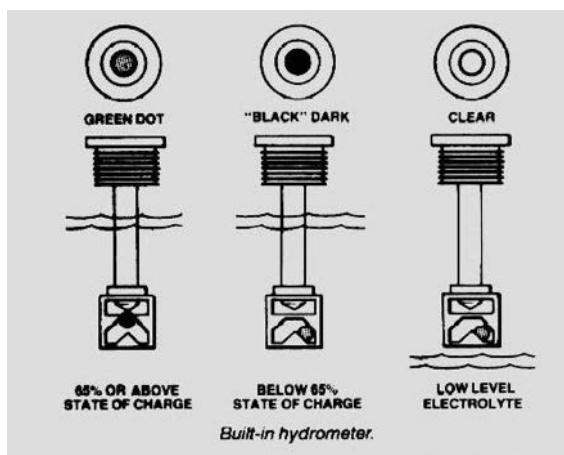

_____ 3. Determine the cold cranking amperes (CCA) of the battery = _____.

(The charge rate should be 1% of the CCA. For example, a battery with a 500 CCA rating should be charged at 5 ampere rate.) Charge Rate = $\frac{CCA}{100}$

100

_____ 4. Determine the reserve capacity in minutes = _____.

(The charge rate can be determined by dividing the reserve capacity of the battery in minutes by 30. For example, a 180-minute battery should be charged at 6 ampere rate: $180/30 = 6$).

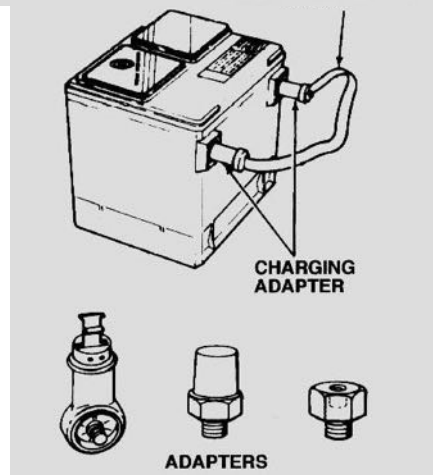

$$\text{Charge Rate} = \frac{\text{Reserve Capacity}}{30}$$

_____ 5. The battery should be charged at _____ amperes (CCA method) or at _____ amperes (reserve capacity method).