

Rear Disc Parking Brake Adjustment

Meets NATEF Task: (A5-D-10) Retract caliper piston on an integrated parking brake system.
(P-3)

Name _____ Date _____ Time on Task _____

Make/Model/Year _____ VIN _____ Evaluation: 4 3 2 1

Many vehicles equipped with rear disc brakes use a mechanical activated parking brake that is integral with the caliper. Most are designed to be self-adjusting by adjusting when excessive brake pad-to-rotor clearance occurs.

_____ 1. Check the service information for the specified rear disc brake parking brake adjustment procedure.

_____ 2. Check the number of “clicks” of the parking brake.
 _____ Number of clicks (should be between 3 and 9)
 OK _____ NOT OK _____

If over 10 clicks is needed to set the parking brake, the rear disc brake caliper needs adjustment.

_____ 3. Hoist the vehicle safely and remove both rear wheels.

_____ 4. Carefully inspect the rear disc brakes for damage and measure the pads for excessive wear.

OK _____ NOT OK _____

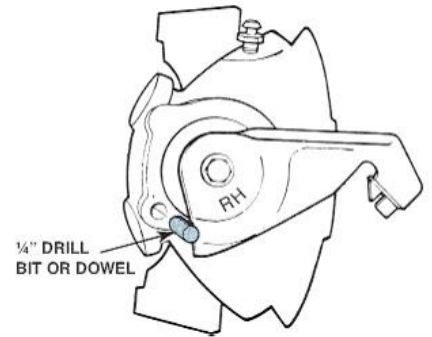

Replace the pads if worn to the minimum allowable thickness.

_____ 5. If the disc brake pads are serviceable, operate the parking brake lever using the appropriate size wrench on the actuating arm retaining bolt/nut while lightly tapping on the caliper using a dead blow plastic hammer. The adjusting mechanism should cause the piston to be repositioned with the correct pad to rotor clearance.

OK _____ NOT OK _____

If the proper clearance is not achieved, replacement of the calipers is required.