

Drum Brake Identification

Meets NATEF Task: (A5-A-3) Research applicable vehicle and service information, such as brake system operation, vehicle service history, service precautions and TSBs. (P-1)

Name _____ Date _____ Time on Task _____

Make/Model/Year _____ VIN _____ Evaluation: 4 3 2 1

_____ 1. Check service information and determine the following information regarding the drum brake design and features for the vehicle (check all that apply):

- ___ Dual servo
- ___ Leading trailing
- ___ Clip-on wheel cylinder
- ___ Bolted on wheel cylinder
- ___ Cast iron brake drum
- ___ Aluminum brake drum
- ___ Single U-spring design
- ___ Clip-type holddown
- ___ Coil-spring holddown
- ___ Cable-operated self adjust
- ___ Other (describe) _____
- _____
- _____

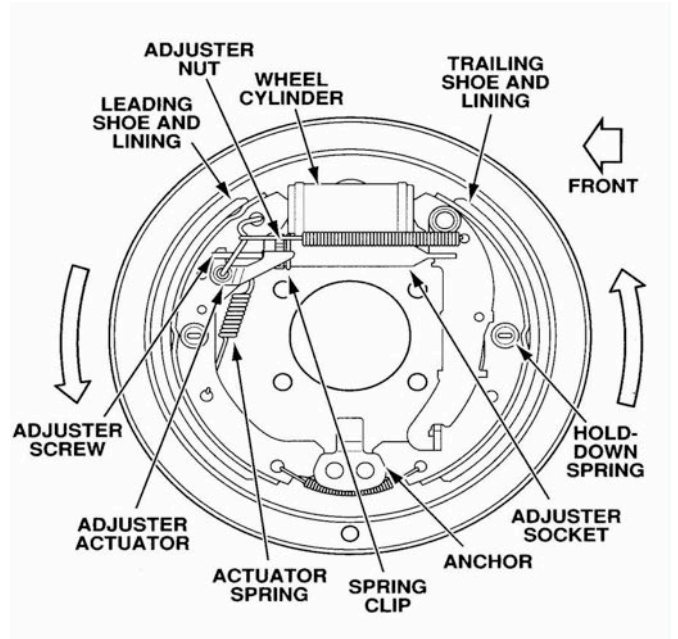

_____ 2. What is the brake drum diameter?

_____ 3. What is the minimum allowable lining thickness?

_____ 4. What is the maximum allowable brake drum diameter?
