

---

---

---

---

---

---

---

---

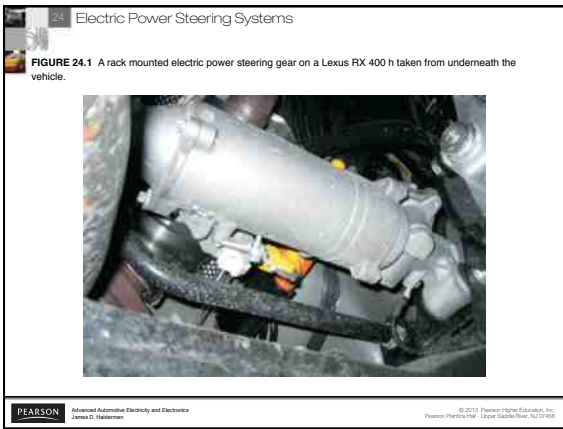

---

---

---

---

---

---

---

---



---

---

---

---

---

---

---

---

24 Electric Power Steering Systems

**FIGURE 24.3** A Toyota Prius EPS assembly. (Courtesy of Tony Martin)



PEARSON Advanced Automotive Electricity and Electronics  
James D. Halperman © 2013 Pearson Higher Education, Inc.  
Pearson Prentice Hall, Upper Saddle River, NJ 07458

---

---

---

---

---

---

---

---

24 Electric Power Steering Systems

**NOTE:** If the steering wheel, steering column, or steering gear is removed or replaced, the system must be recalibrated, which resets the zero point of the torque sensors.

PEARSON Advanced Automotive Electricity and Electronics  
James D. Halperman © 2013 Pearson Higher Education, Inc.  
Pearson Prentice Hall, Upper Saddle River, NJ 07458

---

---

---

---

---

---

---

---

24 Electric Power Steering Systems

**FIGURE 24.4** The torque sensor converts the torque the driver is applying to the steering wheel into a voltage signal.

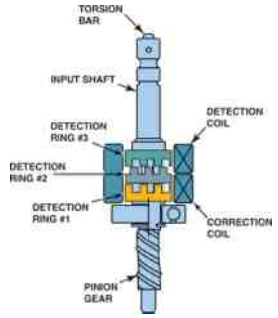

PEARSON Advanced Automotive Electricity and Electronics  
James D. Halperman © 2013 Pearson Higher Education, Inc.  
Pearson Prentice Hall, Upper Saddle River, NJ 07458

---

---

---

---

---

---

---

---

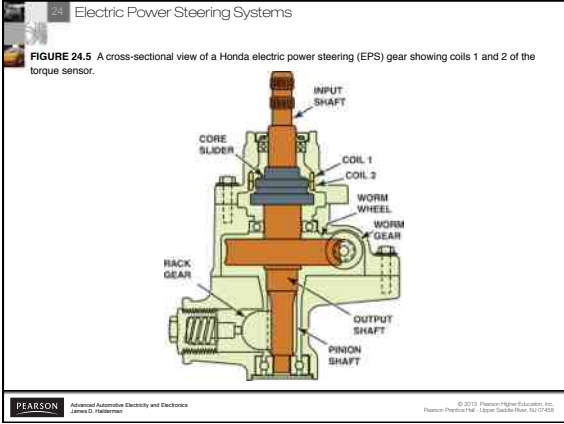

---

---

---

---

---

---

---

---

---

---

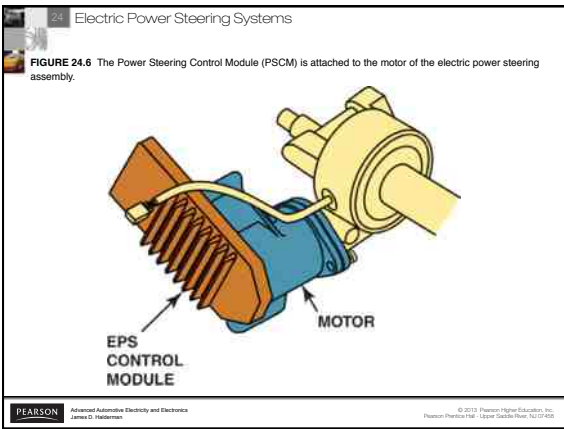

---

---

---

---

---

---

---

---

---

---

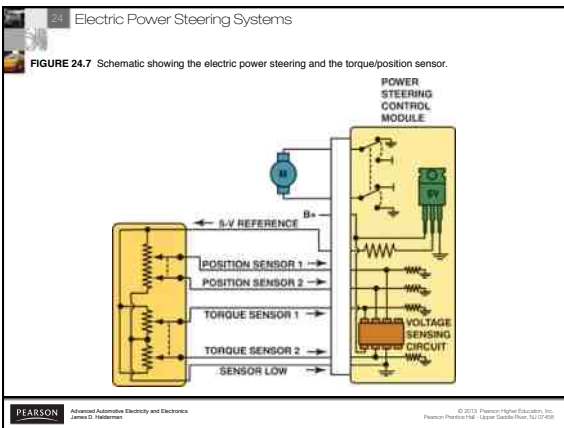

---

---

---

---

---

---

---

---

---

---

24 Electric Power Steering Systems

**REAL WORLD FIX**

**The Hard Steering Chevrolet HHR**

The owner of a Chevrolet HHR complained that the steering wheel was harder to turn after the battery was jump started. The tow truck driver did not know what to do and advised the owner to take it to a shop to have it looked at but the driver did not think that jump starting the vehicle could affect the power steering. A technician at the shop determined that the electric power steering did not work because of a blown fuse. Apparently, the vehicle was jump started by connecting the positive jump cable to the main terminal toward the rear of the engine compartment instead of the terminal designed to be used to jump start the vehicle as the battery is located at the rear of this vehicle. **SEE FIGURE 24-8.**

After the blown fuse was replaced, the electric power steering worked correctly.

PEARSON Advanced Automotive Electricity and Electronics James D. Halperin © 2013 Pearson Higher Education, Inc. Pearson Education, Inc. Upper Saddle River, NJ 07088

---

---

---

---

---

---

---

---

---

---

24 Electric Power Steering Systems

**FIGURE 24.8** The blown fuse is the yellow 60-amp fuse next to the terminal at the top.

PEARSON Advanced Automotive Electricity and Electronics James D. Halperin © 2013 Pearson Higher Education, Inc. Pearson Education, Inc. Upper Saddle River, NJ 07088

---

---

---

---

---

---

---

---

---

---

24 Electric Power Steering Systems

**CHART 24.1** Sample diagnostic trouble codes (DTCs) for the electric power steering system.

| DIAGNOSTIC TROUBLE CODE (DTC) | DESCRIPTION OF FAULT                   |
|-------------------------------|--|
| C1511; C1512; C1513; C1514    | Torque sensor fault detected           |
| C 1521                        | Short in motor circuit                 |
| U0073                         | EPS control module lost communications |

**CHART 24-1**

PEARSON Advanced Automotive Electricity and Electronics James D. Halperin © 2013 Pearson Higher Education, Inc. Pearson Education, Inc. Upper Saddle River, NJ 07088

---

---

---

---

---

---

---

---

---

---

24 Electric Power Steering Systems

**FIGURE 24.9** An electro-hydraulic power steering assembly on a Chevrolet hybrid pickup truck.



**PEARSON** Advanced Automotive Electricity and Electronics  
James G. Halperin

© 2013 Pearson Higher Education, Inc.  
Pearson Education, Inc., 501 Boylston Street, Boston, MA 02116

---

---

---

---

---

---

---

---